

WT1250 Water Trailer Owner's Manual



WARNING

This Owner's Manual contains safety information and instructions for your trailer.

You must read this manual before loading or towing your trailer.

You must follow all safety precautions and instructions.

Magna Manufacturing

**548 Bourquin Road
Estevan, SK S4A 2A7, Canada
(306)994-2400**

www.magnamfg.com



1. Introduction	5
2. Safety	6
2.1 Safety Alert Symbols And Signal Words	6
2.2 Major Hazards	6
2.2.1 Improper Sizing Of Trailer To Tow Vehicle	6
2.2.2 Driving Too Fast	6
2.2.3 Adjust Driving When Towing Trailer	7
2.2.4 Trailer Not Properly Coupled To Hitch	7
2.2.5 Proper Use Of Safety Chains	8
2.2.6 Proper Connection Of Breakaway Brake	8
2.2.7 Matching Trailer And Hitch	8
2.2.8 Worn Tires, Loose Wheels And Lug Nuts	8
2.2.9 Improper Loading	9
2.2.10 Unsafe Load Distribution	10
2.2.11 Shifting Cargo	10
2.2.12 Inappropriate Cargo	10
2.2.13 Inoperable Brakes Or Lights	11
2.2.14 Trailer Modifications	11
2.2.15 Trailer Towing Guide	11
2.2.16 Safe Trailer Towing Guidelines	12
2.2.17 Safety Warning Labels On Your Trailer	13
2.2.18 Reporting Safety Defects	16
3. Tire Safety Information	17
3.1 Trailer Tire Information	17
3.2 Steps For Determining Correct Load Limit - Trailer	18
3.2.1 Trailers 10,000 Pounds GVWR Or Less	18
3.2.2 Trailers Over 10,000 Pounds GVWR	18
3.3 Steps For Determining Correct Load Limit - Tow Vehicle	19
3.4 Glossary Of Tire Terminology	19
3.5 Tire Safety - Everything Rides On It	21
3.5.1 Safety First - Basic Tire Maintenance	22
3.5.2 Finding Your Vehicle's Recommended Tire Pressure And Load Limits	22
3.5.3 Understanding Tire Pressure And Load Limits	22
3.5.4 Safety First - Basic Tire Maintenance	22
3.5.5 Steps For Maintaining Proper Tire Pressure	22
3.5.6 Tire Size	23
3.5.7 Tire Tread	23
3.5.8 Tire Balance And Wheel Alignment	23
3.5.9 Tire Repair	23
3.5.10 Tire Fundamentals	23
3.5.10.1 Information on Passenger Vehicle Tires	23
3.5.10.2 UTQGS Information	24

Contents

3.5.10.3 Additional Information On Light Truck Tires	24
3.5.10.4 Tire Safety Tips	25
4. Coupling To Tow Vehicle	26
4.1 Tow Vehicle And Hitch	26
4.1.1 Trailer Information	26
4.1.2 Tow Vehicle	26
4.2 Coupling And Uncoupling The Trailer	26
4.3 Couple Trailer To Tow Vehicle	27
4.3.1 Ball Hitch Coupler	27
4.3.1.1 Before Coupling Trailer To Tow Vehicle	28
4.3.1.2 Prepare Coupler And Hitch	28
4.3.1.3 Couple Trailer To Tow Vehicle	28
4.3.2 Trailer With Ring And Pintle Coupler	29
4.3.2.1 Before Coupling Trailer To Tow Vehicle	29
4.3.2.2 Prepare Ring And Pintle	29
4.3.2.3 Couple Trailer To Tow Vehicle	30
4.3.3 Connect Safety Chains	30
4.3.4 Connect Electrical Cable	31
4.3.5 Attach Breakaway Brake Lanyard	31
4.3.5.1 Test Electric Brakes	31
4.3.5.2 Test Electric Breakaway Brakes	31
4.3.5.3 Test Surge Brakes (If Equipped)	32
4.3.5.4 Test Surge Breakaway System	33
4.4 Uncouple Trailer	33
4.5 Tongue Weight	33
4.5.1 Checking Tongue Weight	34
4.6 Adjust Hitch Height (If Equipped)	34
5. Loading And Unloading	36
5.1 Loading Trailer	36
5.1.1 Preparing Trailer For Loading	36
5.1.2 Loading A Rigid Deck Trailer	36
5.1.3 Loading A Tilt Deck Trailer	37
5.1.3.1 Manual Tilt Trailer	37
5.1.3.2 Hydraulic Tilt Trailer	38
5.2 Unload Trailer	38
5.2.1 Unload Manual Tilt Trailer	38
5.2.2 Unload Hydraulic Tilt Trailer	38
5.3 Hydraulic Components	39
5.4 Securing Cargo	39
6. Pre-Tow Checklist	40
6.1 Pre-Tow Checklist	40
6.2 Make Regular Stops	40

7. Breaking In A New Trailer	41
7.1 Retighten Lugs At First 10, 25 & 50 Miles.....	41
7.2 Adjust Brake At First 200 Miles	41
7.3 Synchronizing Brake Systems	41
8. Accessories	42
8.1 Accessory Battery	42
9. Inspection, Service And Maintenance	43
9.1 Inspection, Service & Maintenance Summary Charts.....	43
9.2 Inspection And Service Instructions.....	46
9.2.1 Trailer Structure	46
9.2.1.1 Fasteners And Frame Members	46
9.2.1.2 Welds	46
9.2.2 Trailer Brakes - Electric	46
9.2.2.1 Brake Discs, Shoes And Drums	46
9.2.2.2 Manually Adjusting Brake Shoes	47
9.2.2.3 Electric Brakes	47
9.2.2.4 Tow Vehicle Operated Electric Brakes	47
9.2.2.5 Electric Brake Magnets	47
9.2.3 Trailer Brakes - Surge (If Equipped)	47
9.2.3.1 Surge Brake Master Cylinder	47
9.2.3.2 Hydraulic Surge Brake	48
9.2.3.3 Master Cylinder Bleeding	48
9.2.4 Trailer Connection To Tow Vehicle	48
9.2.4.1 Coupler And Ball	48
9.2.4.2 Ring And Pintle	49
9.2.5 Landing Leg Or Jack	49
9.2.6 Lights And Signals	49
9.2.7 Wheel Rims.....	49
9.2.8 Tires	49
9.2.9 Wheel Bearings	50
9.2.10 Lubrication	50
9.2.11 Hydraulic Reservoir	50
9.2.12 Lug Nuts Or Bolts	50

1. Introduction

Congratulations on the purchase of your trailer. We believe you will be happy and completely satisfied with your purchase. Our goal is to provide a valued customer a quality trailer at a reasonable price.

For your safety, read and understand this manual before operating your trailer. If there are any questions about information in this manual, please consult your dealer.

When calling about your trailer, please have the VIN number available for the dealer. The VIN number is normally on the front left side of the trailer.

For future reference, please write your VIN number in the space below:

This manual covers the basic trailer. You must read, understand and follow the instructions given by the trailer manufacturer, tow vehicle and trailer hitch manufacturers. Keep all manuals provided with your trailer in a safe place at all times.

2. Safety

2.1 Safety Alert Symbols And Signal Words

An Owner's Manual that provides general trailer information cannot cover all of the specific details necessary for the proper combination of every trailer, tow vehicle and hitch. You must read, understand and follow the instructions given by the tow vehicle and trailer hitch manufacturers, as well as the instructions in this manual.

Our trailers are built with components produced by various manufacturers. Some of these items have separate instruction manuals. Where this manual indicates that you should read another manual, and you do not have that manual, contact your dealer for assistance.

The safety information in this manual is denoted by the safety alert symbol:



This symbol means ATTENTION! BECOME ALERT! YOUR SAFETY IS INVOLVED!

The level of risk is indicated by the following signal words:

 DANGER
DANGER - Indicates a hazardous situation, which, if not avoided, WILL result in death or serious injury.

 WARNING
WARNING - Indicates a hazardous situation, which, if not avoided, could result in death or serious injury.

 CAUTION
CAUTION - Indicates a hazardous situation, which, if not avoided, could result in minor or moderate injury.

NOTICE

NOTICE - Indicates a situation that could result in damage to the equipment or other property.

2.2 Major Hazards

Loss of control of the trailer or trailer/tow vehicle combination can result in death or serious injury. The most common causes for loss of control of the trailer are:

- Improper sizing the trailer for the tow vehicle, or vice versa.
- Excessive Speed: Driving too fast for the conditions.
- Improper braking and steering under sway conditions
- Overloading and/or improper weight distribution.
- Not keeping lug nuts tight.
- Failure to adjust driving behavior when towing a trailer.
- Not maintaining proper tire pressure
- Improper or mis-coupling of the trailer to the hitch.

2.2.1 Improper Sizing Of Trailer T o Tow Vehicle

Trailers that weigh too much for the tow vehicle can cause stability problems, which can lead to death or serious injury. The additional strain put on the engine and drive-train may lead to serious tow vehicle maintenance problems.

Do not exceed the maximum towing capacity of your tow vehicle. The towing capacity of your tow vehicle, in terms of maximum Gross Trailer Weight (GTW) and maximum Gross Combined Weight Rating (GCWR) can be found in the tow vehicle Owner's Manual.

 DANGER
Use of an under-rated hitch, ball or tow vehicle can result in loss of control leading to death or serious injury.
Make certain your hitch and tow vehicle are rated for your trailer.

2.2.2 Driving T oo Fast

With ideal road conditions, the maximum recommended speed for safely towing a trailer is 55 mph. Driving too fast can cause the trailer to sway, thus increasing

the possibility for loss of control. Also your tires may overheat, increasing the possibility of a blowout.

WARNING

Driving too fast for conditions can result in loss of control and cause death or serious injury.

Adjust speed down when towing trailer.

2.2.3 Adjust Driving When Towing Trailer

When towing a trailer, you will have decreased acceleration, increased stopping distance, and increased turning radius.

The trailer will change the handling characteristics of the tow vehicle, making it more sensitive to steering inputs and more likely to be pushed around in windy conditions or when being passed by large vehicles. In addition, you will need a longer distance to pass, due to slower acceleration and increased length. With this in mind:

- When encountering trailer sway, take your foot off the accelerator, and steer as little as possible in order to stay on the road. Use small “trim-like” steering adjustments. Do not attempt to steer out of the sway; you’ll only make it worse. Also do not apply the tow vehicle brakes to correct trailer swaying. On the other hand, application of the trailer brakes alone will tend to straighten out the combination, especially when going downhill.
- Check rearview mirrors frequently to observe trailer and traffic.
- Be aware of trailer height, especially when approaching bridges, roofed areas and trees.
- Be alert for slippery conditions. You are more likely to be affected by slippery road surfaces when driving a tow vehicle with a trailer, than driving a tow vehicle without a trailer.
- Anticipate the trailer “swaying.” Swaying can be caused by excessive steering, wind gusts, roadway edges, or by the trailer reaction to the pressure wave created by passing trucks and busses.
- Use lower gear when driving down steep or long grades. Use the engine and transmission as a brake. Do not ride the brakes, as they can overheat and become ineffective.

2.2.4 Trailer Not Properly Coupled To Hitch

It is critical that the trailer be securely coupled to the hitch, and that the safety chains and emergency breakaway brake lanyard are correctly attached. Uncoupling may result in death or serious injury to you and to others.

WARNING

Proper selection and condition of the coupler and hitch are essential to safely towing a trailer.

A loss of coupling may result in death or serious injury.

Hitch size must match coupler size.

Be sure hitch load rating is equal to or greater than load rating of the coupler.

Be sure hitch components are tight before coupling trailer to tow vehicle.

Observe hitch for wear, corrosion and cracks before coupling. Replace worn, corroded or cracked hitch components before coupling trailer to tow vehicle.

WARNING

An improperly coupled trailer can result in death or serious injury. Do not move the trailer until:

- **Coupler is secured and locked to hitch.**
- **Safety chains are secured to tow vehicle.**
- **Trailer jack(s) are fully retracted.**
- **Trailer brakes are checked.**
- **Tires and wheels are checked.**
- **Breakaway switch is connected to tow vehicle;**
- **The trailer lights are connected and checked.**
- **Load is secured to trailer.**

2.2.5 Proper Use Of Safety Chains

Safety chains are provided so that control of the trailer can be maintained if your trailer comes loose from the hitch.

WARNING

Improper rigging of the safety chains can result in loss of control of the trailer and tow vehicle, leading to death or serious injury, if the trailer uncouples from the tow vehicle.

Cross chains underneath hitch and coupler with enough slack to permit turning and to hold tongue up, if the trailer comes loose.

Fasten chains to frame of tow vehicle.

Do not fasten chains to any part of the hitch unless the hitch has holes or loops specifically for that purpose.

2.2.6 Proper Connection Of Breakaway Brake

If equipped with brakes, your trailer will be equipped with a breakaway brake system that can apply the brakes on your trailer if your trailer comes loose from the hitch. You may have a separate set of instructions for the breakaway brake if the trailer is so equipped. The breakaway brake system, including battery, must be in good condition and properly rigged to be effective.

WARNING

An ineffective or inoperative breakaway brake system can result in a runaway trailer, leading to death or serious injury if the coupler or hitch fails.

Breakaway lanyard must be connected to the tow vehicle, NOT to any part of the hitch.

Before towing trailer, test the function of the breakaway brake system. If the breakaway brake system is not working, do not tow the trailer. Have it serviced or repaired.

2.2.7 Matching Trailer And Hitch

DANGER

Be sure hitch and tow vehicle are rated for the Gross Vehicle Weight Rating (GVWR) of your trailer.

Use of a hitch with a load rating less than the load rating of the trailer can result in loss of control and may lead to death or serious injury.

Use of a tow vehicle with a towing capacity less than the load rating of the trailer can result in loss of control, and may lead to death or serious injury.

2.2.8 Worn Tires, Loose Wheels And Lug Nuts

Inspect all trailer tires before each tow. If a tire has a bald spot, bulge, cut, cracks, or is showing any cords, replace the tire before towing.

If a tire has uneven tread wear, take the trailer to a trailer service center for diagnosis. Uneven tread wear can be caused by tire imbalance, axle misalignment or incorrect inflation.

Tires with too little tread will not provide adequate frictional forces on wet roadways and can result in loss of control, leading to death or serious injury.

Improper tire pressure causes increased tire wear and may reduce trailer stability, which can result in a tire blowout or possible loss of control. Therefore, before each tow you must also check the tire pressure.

The proper tire pressure is listed on the Certification / VIN label, normally mounted on the front left side of the trailer, and should be checked when tires are cold. Allow 3 hours cool-down after driving as much as 1 mile at 40 mph before checking tire pressure.

WARNING

Inflate tires to pressure stated on the Certification / VIN label.

Improper tire pressure may cause unstable trailer. Blowout and loss of control may occur. Death or serious injury can result.

Make sure of proper tire pressure before towing trailer.

The tightness of the wheel nuts or bolts is very important in keeping the wheels properly seated to the hub. Before each tow, check to make sure they are tight.

WARNING

Metal creep between the wheel rim and wheel nuts or bolts may cause rim to loosen.

Death or injury can occur if wheel comes off.

Tighten lug nuts or bolts before each tow.

The proper tightness (torque) for wheel nuts or bolts and tightening sequence is listed in the Inspection, Service and Maintenance section of this manual. Use a torque wrench to tighten the lug nuts and use the crisscross star pattern sequence. Improper tightening of the lug nuts voids the axle warranty.

Wheel nuts or bolts are also prone to loosen after first being assembled. When driving a new trailer (or after wheels have been remounted), check to make sure they are tight after the first 10, 25 and 50 miles of driving and before each tow thereafter.

Failure to perform this check can result in a wheel separating from the trailer and a crash, leading to death or serious injury.

WARNING

Wheel nuts or bolts are prone to loosen after being first assembled. Death or serious injury can result.

Check wheel nuts or bolts for tightness on a new trailer, and after re-mounting a wheel at 10, 25 and 50 miles.

WARNING

Inadequate wheel nut or bolt torque can cause a wheel to separate from the trailer, leading to death or serious injury.

Verify wheel nuts or bolts are tight before each tow.

2.2.9 Improper Loading

The total weight of the load you put on the trailer, plus the empty weight of the trailer itself, must not exceed the trailer's Gross Vehicle Weight Rating (GVWR).

If you do not know the empty weight of the trailer plus the cargo weight, you must weigh the loaded trailer at a commercial scale. In addition, you must distribute the load in the trailer such that the load on any axle does not exceed the Gross Axle Weight Rating (GAWR).

If your trailer is equipped with a Tire & Loading Information Placard, mounted next to the Certification / VIN label, the cargo capacity weight stated on that placard is only a close estimate. The GVWR and GAWR are listed on the Certification / VIN label normally located on the front left side of the trailer.

WARNING

An overloaded trailer can result in failure or loss of control of the trailer, leading to death or serious injury.

Never load a trailer so that the weight on any tire exceeds its rating.

Never exceed the trailer Gross Vehicle Weight Rating (GVWR) or axle Gross Axle Weight Rating (GAWR).

2.2.10 Unsafe Load Distribution

Improper front / rear load distribution can lead to an unstable trailer or poor tow vehicle handling. Poor trailer stability results from tongue weights that are too low, and poor tow vehicle stability results from tongue weights that are too high.

Refer to the “Loading And Unloading” section for more information.

In the following table, the second column shows the rule of thumb percentage of total weight of the trailer plus its cargo (Gross Trailer Weight, or “GTW”) that should appear on the tongue of the trailer. For example, a large trailer with a loaded weight of 6,000 pounds, should have 10-15% of 6,000 pounds (600-900 lbs.) on the hitch.

Tongue Weight as a Percentage of Loaded Trailer Weight	
Type of Hitch	Percentage
Ball Hitch or Ring & Pintle	10-15% for large trailers 6-10% for small trailers

The numbers quoted are for example purposes only and should be tailored to the specific trailer.

For questions regarding the actual percent of tongue weight for the trailer, check with the manufacturer for specifics.

After loading, be sure to check that none of the axles are overloaded.

Uneven left / right load distribution can cause tire, wheel, axle or structural failure.

Be sure your trailer is evenly loaded left / right. Towing stability also depends on keeping the center of gravity as low as possible.



WARNING

Improper tongue weight (load distribution) can result in loss of control of the trailer, leading to death or serious injury.

Make certain that tongue weight is within the allowable range.

Be sure to:

- **Distribute the load evenly, right and left.**
- **Keep the center of gravity low.**
- **Distribute the load front-to-rear to provide proper tongue weight (see chart).**

2.2.11 Shifting Cargo

Since the trailer “ride” can be bumpy and rough, you must secure the cargo so that it does not shift while the trailer is being towed.



WARNING

A shifting load can result in failure, or to loss of control of the trailer, and can lead to death or serious injury.

You must tie down all loads with proper sized fasteners, chains, straps, etc. to prevent the load from shifting while towing.

2.2.12 Inappropriate Cargo

The trailer may be designed for specific cargo. If your trailer is designed for specific cargo, only carry that cargo in the trailer. A trailer must not be used to carry certain items, such as people, containers of hazardous substances or containers of flammable substances.



WARNING

Do not transport people on your trailer. Besides putting their lives at risk, the transport of people on a trailer is illegal.



WARNING

Do not transport flammable, explosive, poisonous or other dangerous materials on your trailer.

The exception is fuel in the tank of a vehicle or equipment being hauled.

2.2.13 Inoperable Brakes Or Lights

If your trailer has electric brakes, your tow vehicle will have an electric brake controller that sends power to the trailer brakes.

Before towing the trailer, you must operate the brake controller while trying to pull the trailer in order to confirm that the electric brakes operate. While towing the trailer at less than 5 mph, manually operate the electric brake controller in the tow vehicle cab. You should feel the operation of the trailer brakes.

If your trailer has hydraulic “surge” brakes, pull the emergency breakaway brake lanyard to check the operation of the surge mechanism.

Be sure that the electric brakes and all of the lights on your trailer are functioning properly before towing the trailer. Electric brakes and lights on a trailer are controlled via a connection to the tow vehicle, generally a multi-pin electrical connector.



WARNING

Improper electrical connection between the tow vehicle and the trailer will result in inoperable lights and electric brakes, and can lead to collision.

Before each tow:

- **Check that the electric brakes work by operating the brake controller inside the tow vehicle.**
- **Check that all lights and turn signals work.**

You must provide mirrors that allow you to safely observe approaching traffic. Standard mirrors usually do not provide adequate visibility for viewing traffic to the sides and rear a towed trailer.

2.2.14 Trailer Modifications

Modification of the trailer structure or alteration of your trailer can make the trailer unsafe and will void all warranty options. Before making any alteration to the trailer, contact your dealer or the manufacturer and describe the alteration you are contemplating.

2.2.15 Trailer Towing Guide

Driving a vehicle with a trailer in tow is vastly different from driving the same vehicle without a trailer in tow. Acceleration, maneuverability and braking are all diminished with a trailer in tow. It takes longer to get up to speed; you need more room to turn and pass, and more distance to stop when towing a trailer.

You will need to spend time adjusting to the different feel and maneuverability of the tow vehicle with a loaded trailer. Because of the significant differences in all aspects of maneuverability when towing a trailer, the hazards and risks of injury are also much greater than when driving without a trailer.

You are responsible for keeping your vehicle and trailer in control, and for all the damage that is caused if you lose control of your vehicle and trailer.

Find an open area with little or no traffic for your first practice. Before you start towing the trailer, you must follow all of the instructions for inspection, testing, loading and coupling. Also, before you start towing, adjust the mirrors so you can see the trailer as well as the area to the rear of it.

Drive slowly at first, 5 mph or so, and turn the wheel to get the feel of how the tow vehicle and trailer combination responds. Next, make some right and left hand turns. Watch in your side mirrors to see how the trailer follows the tow vehicle. Turning with a trailer attached requires more room.

Stop the rig a few times from speeds no greater than 10 mph. If your trailer is equipped with brakes, try using different combinations of trailer/electric brake and tow vehicle brake. Note the effect that the trailer brakes have when they are the only brakes used. When properly adjusted, the trailer brakes will come on just before the tow vehicle brakes.

It will take practice to learn how to back up a tow vehicle with a trailer attached. Take it slow. Before backing up, get out of the tow vehicle and look behind the trailer to make sure that there are no obstacles.

Some drivers place their hands at the bottom of the steering wheel, and while the tow vehicle is in reverse, “think” of the hands as being on the top of the wheel. When the hands move to the right (counter-clockwise, as you would do to turn the tow vehicle to the left when moving forward), the rear of the trailer moves to the right.

Conversely, rotating the steering wheel clockwise with your hands at the bottom of the wheel will move the rear of the trailer to the left, while backing up. Be careful not to allow the trailer to turn too much, because it will hit the rear of the tow vehicle. To straighten the rig, either pull forward, or turn the steering wheel in the opposite direction.

2.2.16 Safe Trailer Towing Guidelines

Before towing, check coupling, safety chain, brakes, tires, wheels and lights.

Check the lug nuts or bolts for tightness.
Recheck the load tie downs to make sure the load will not shift during towing.

Check coupler tightness after towing 50 miles.

Adjust the brake controller to engage the trailer brakes before the tow vehicle brakes. Follow the brake controller manufacturer’s literature.

Use your mirrors to verify that you have room to change lanes or pull into traffic.

Use your turn signals well in advance.

Allow plenty of stopping space for your trailer and tow vehicle.

Use lower gears for climbing and descending grades.

Do not ride the brakes while descending grades; they may get so hot that they stop working. Then you will potentially have a runaway tow vehicle and trailer.

Do not apply the tow vehicle brakes to correct extreme trailer swaying. Instead, lightly apply the trailer brakes with the hand controller.

Make regular stops, about once each hour. Confirm that:

- The coupler is secure to the hitch and is locked.
- Electrical connectors are made.
- There is appropriate slack in safety chains.
- There is appropriate slack in breakaway lanyard.

- The tires are not visibly low on pressure.
- The cargo is secure and in good condition.

Slow down for bumps in the road.

Do not brake while in a curve unless absolutely necessary. Instead, slow down before you enter the curve.

Do not drive so fast that the trailer begins to sway due to speed. Generally never drive faster than 55 m.p.h.

Allow plenty of room for passing. A rule of thumb is that the passing distance with a trailer is 4 times the passing distance without a trailer.

2.2.17 Safety Warning Labels On Your Trailer

Depending on trailer configuration, your trailer may not be equipped with all safety labels shown.

<h3>⚠ WARNING</h3>	
<p>Uncoupling will cause trailer to come loose from tow vehicle. You must:</p> <ol style="list-style-type: none"> 1. CHECK that ball LOAD RATING is same as or greater than coupler LOAD RATING. 2. CHECK that ball SIZE is same as coupler. 3. CLOSE COUPLER CLAMP on ball. 4. LIFT coupler upwards to test that it will not separate from ball. 5. LOCK coupler clamp with pin or padlock. <p>© 2002 NATM</p>	

<h3>⚠ WARNING</h3>	
<p>Uncoupling will cause trailer to come loose from tow vehicle. You must:</p> <ol style="list-style-type: none"> 1. CHECK that ball LOAD RATING is same or greater than coupler LOAD RATING. 2. CHECK that ball SIZE is same as coupler. 3. CLOSE COUPLER CLAMP on ball. 4. LIFT coupler upwards to test that it will not separate from ball. 5. LOCK sleeve with pin or padlock. <p>© 2002 NATM</p>	

<h3>⚠ WARNING</h3>	
<p>Uncoupling will cause trailer to come loose from tow vehicle.</p> <ol style="list-style-type: none"> 1. CHECK that pintle LOAD RATING is same or greater than ring LOAD RATING. 2. LOCK the clamp in place using a pin or lock. <p>© 2002 NATM</p>	

<h3>⚠ WARNING</h3>	
<p>ALWAYS use safety chains. Chains hold trailer if connection fails. You must:</p> <ol style="list-style-type: none"> 1. CROSS chains underneath coupler. 2. ALLOW slack for trailer to turn. 3. ATTACH chain hooks securely to tow vehicle frame. <p>© 2002 NATM</p>	

<h3>⚠ WARNING</h3>	
<p>ALWAYS use safety chains. Chains hold trailer if connection fails. You must:</p> <ol style="list-style-type: none"> 1. CROSS chains underneath coupler. 2. ALLOW slack for trailer to turn. 3. ATTACH chain hooks securely to tow vehicle frame. <p>© 2002 NATM</p>	

<h2 style="margin: 0;">⚠ WARNING</h2>	<p style="text-align: center;">ATTACH TO TOW VEHICLE FRAME</p>
<p>ALWAYS use safety chains. Chains hold trailer if connection fails. You must:</p> <ol style="list-style-type: none"> 1. CROSS chains underneath coupler. 2. ALLOW slack for trailer to turn. 3. ATTACH chain hooks securely to tow vehicle frame. 	UT0034

<h2 style="margin: 0;">⚠ WARNING</h2>	
<p>Trailer can roll if it comes loose. Safety brake applies when chain pulls brake lever.</p> <ol style="list-style-type: none"> 1. ATTACH brake CHAIN securely to tow vehicle so lever will be pulled if trailer separates. 2. CHECK brake fluid level. 3. DO NOT TOW trailer if brake fluid is NOT FULL. 	UT0028

<h2 style="margin: 0;">⚠ WARNING</h2>	<p style="text-align: center;">PIN PULLED OUT, ONLY TO TEST BRAKES</p>
<p>Trailer can roll if it comes loose. Electric safety brake applies when cable pulls pin out of switch box:</p> <ol style="list-style-type: none"> 1. PULL hard to get pin out of switch box. 2. CHECK brake by PULLING TRAILER with tow vehicle. 3. ATTACH pin CABLE to tow vehicle so pin will be pulled out if trailer separates. 4. Promptly REPLACE pin in switch box. 	UT0037

<h2 style="margin: 0;">⚠ WARNING</h2>	<p style="text-align: center;">PIN PULLED OUT, ONLY TO TEST BRAKES</p>
<p>Trailer can roll if it comes loose. Electric safety brake applies when cable pulls pin out of switch box:</p> <ol style="list-style-type: none"> 1. PULL hard to get pin out of switch box. 2. CHECK brake by PULLING TRAILER with tow vehicle. 3. ATTACH pin CABLE to tow vehicle so pin will be pulled out if trailer separates. 4. Promptly REPLACE pin in switch box. 	UT0035

<h2 style="margin: 0;">⚠ WARNING</h2>	<div style="display: flex; justify-content: space-around;"> <div style="text-align: center;"> <p>DISCONNECTED</p> </div> <div style="text-align: center;"> <p>CONNECTED</p> </div> </div>
<p>Lights can prevent trailer from being hit by other vehicles. You must:</p> <ol style="list-style-type: none"> 1. CONNECT trailer and tow vehicle electrical connectors. 2. CHECK all lights: tail lights, turn signal, and brake lights. 3. DO NOT TOW if lights are not working. 	UT0026

<h2 style="margin: 0;">⚠ WARNING</h2>	<p style="text-align: center;">PIN PULLED OUT, ONLY TO TEST BRAKES</p>
<p>Trailer can roll if it comes loose. Electric safety brake applies when cable pulls pin out of switch box.</p> <ol style="list-style-type: none"> 1. PULL hard to get pin out of switch box. 2. CHECK brake by PULLING TRAILER with tow vehicle. 3. ATTACH pin CABLE to tow vehicle so pin will be pulled out if trailer separates. 4. Promptly REPLACE pin in switch box. <p>© 2002 NATM</p>	<p>UT0014</p>

<h2 style="margin: 0;">⚠ WARNING</h2>	
<p>Improper loading can cause trailer sway and sudden loss of control. You must:</p> <ul style="list-style-type: none"> • Make certain weight of load plus trailer weight does not exceed trailer's capacity (GVWR-Gross Vehicle Weight Rating). • Load heavier items in front of wheels. • Load evenly side to side. • SECURE load to trailer. <p>© 2002 NATM</p>	<p>UT0017</p>

<h2 style="margin: 0;">⚠ WARNING</h2>	
<p>Tire, wheel or lugnut failure can cause loss of control. Before towing, you must CHECK:</p> <ol style="list-style-type: none"> 1. Tire pressure and tread. 2. Tires and wheels for damage. 3. Lug nuts for tightness. <p style="padding-left: 20px;">For new and remounted wheels, re-tighten lug nuts at the first 10, 25 and 50 miles of driving.</p> <p>© 2002 NATM</p>	<p>UT0019</p>

<h2 style="margin: 0;">⚠ WARNING</h2>	<p style="text-align: center;">MAXIMUM LOADED TRAILER WEIGHT (GVWR) = EQUALS</p> <div style="text-align: center; border: 1px solid black; padding: 5px; margin: 5px 0;"> <p>MAXIMUM CARGO WEIGHT</p> <p>+ PLUS</p> <p>WEIGHT OF EMPTY TRAILER</p> </div>
<p style="text-align: center;">OVERLOAD HAZARD</p> <p style="text-align: center;">RISK OF DEATH DUE TO LOSS OF CONTROL</p> <p style="text-align: center;">NEVER EXCEED GROSS VEHICLE WEIGHT RATING (GVWR)</p> <p>● BEFORE LOADING THE TRAILER FOR THE FIRST TIME, YOU MUST VERIFY ITS CARGO CAPACITY:</p> <ol style="list-style-type: none"> 1. You MUST WEIGH the EMPTY TRAILER. 2. Subtract the weight of the EMPTY TRAILER from the MAXIMUM LOADED TRAILER WEIGHT (GVWR) (see VIN / SERIAL NO. tag). 3. DO NOT LOAD TRAILER BEYOND VERIFIED CARGO CAPACITY. 	<p>291758</p>

If any of these labels are missing or cannot be read, contact your dealer for replacement labels.

2.2.18 Reporting Safety Defects

If you believe that your vehicle has a defect that could cause a crash or could cause injury or death, you should immediately inform the National Highway Traffic Safety Administration (NHTSA) in addition to notifying

Magna Manufacturing
548 Bourquin Road
Estevan, SK S4A 2A7, Canada
(306)994-2400
www.magnamfg.com

If NHTSA receives similar complaints, it may open an investigation, and if it finds that a safety defect exists in a group of vehicles, it may order a recall and remedy campaign. However, NHTSA cannot become involved in individual problems between you, your dealer, or

Magna Manufacturing
548 Bourquin Road
Estevan, SK S4A 2A7, Canada
(306)994-2400
www.magnamfg.com

To contact NHTSA, you may call the Vehicle Safety Hotline toll-free at 1-888-327-4236 (TTY: 1-800-424-9153); or go to <http://www.safercar.gov>; or write to:

Administrator, NHTSA,
1200 New Jersey SE,
Washington, DC 20590.

You can also obtain other information about motor vehicle safety from <http://www.safercar.gov>.

3. Tire Safety Information

This portion of the User's Manual contains tire safety information as required by 49 CFR 575.6.

Section 3.1 contains "Trailer Tire Information".

Section 3.2 contains "Steps for Determining Correct Load Limit - Trailer".

Section 3.3 contains "Steps for Determining Correct Load Limit – Tow Vehicle".

Section 3.4 contains a Glossary of Tire Terminology, including "cold inflation pressure", "maximum inflation pressure", "recommended inflation pressure", and other non-technical terms.

Section 3.5 contains information from the NHTSA brochure entitled "Tire Safety – Everything Rides On It".

This brochure, as well as preceding subsections, describes the following items;

- Tire labeling, including a description and explanation of each marking on the tires, and information about the DOT Tire Identification Number (TIN).
- Recommended tire inflation pressure, including a description and explanation of:
 - A. Cold inflation pressure.
 - B. Vehicle Placard and location on the vehicle.
 - C. Adverse safety consequences of under inflation (including tire failure).
 - D. Measuring and adjusting air pressure for proper inflation.
- Tire Care, including maintenance and safety practices.
- Vehicle load limits, including a description and explanation of the following items:
 - A. Locating and understanding the load limit information, total load capacity, and cargo capacity.
 - B. Calculating total and cargo capacities with varying seating configurations including quantitative examples showing / illustrating how the vehicles cargo and luggage capacity decreases as combined number and size of occupants' increases. This item is also discussed in Section 3.
 - C. Determining compatibility of tire and vehicle load capabilities.
 - D. Adverse safety consequences of overloading on handling and stopping on tires.

3.1 Trailer Tire Information

Trailer tires may be worn out even though they still have plenty of tread left. This is because trailer tires have to carry a lot of weight all the time, even when not in use.

It is actually better for the tire to be rolling down the road than to be idle. During use, the tire releases lubricants that are beneficial to tire life. Using the trailer tires often also helps prevent flat spots from developing.

The main cause of tire failure is improper inflation. Check the cold tire inflation pressures at least once a week for proper inflation levels. "Cold" means that the tires are at the same temperature as the surrounding air, such as when the vehicle has been parked overnight. Wheel and tire manufacturers recommend adjusting the air pressure to the trailer manufacturer's recommended cold inflation pressure, in pounds per square inch (PSI) stated on the vehicle's Federal Certification Label or Tire Placard when the trailer is loaded to its gross vehicle weight rating (GVWR).

If the tires are inflated to less than the recommended inflation level or the GVWR of the trailer is exceeded, the load carrying capacity of the tire could be dramatically affected. If the tires are inflated more than the recommended inflation level, handling characteristics of the tow vehicle/trailer combination could be affected. Refer to the owner's manual or talk to your dealer or vehicle manufacturer if you have any questions regarding proper inflation practices.

Tires can lose air over a period of time. In fact, tires can lose 1 to 3 PSI per month. This is because molecules of air, under pressure, weave their way from the inside of the tire, through the rubber, to the outside. A drop in tire pressure could cause the tire to become overloaded, leading to excessive heat build up. If a trailer tire is under-inflated, even for a short period of time, the tire could suffer internal damage.

High speed towing in hot conditions degrades trailer tires significantly. As heat builds up during driving, the tire's internal structure starts to breakdown, compromising the strength of the tire. It is recommended to drive at moderate speeds.

Statistics indicate the average life of a trailer tire is about five years under normal use and maintenance conditions. After three years, replacing the trailer tires with new ones should be considered, even if the tires have adequate tread depth. Some experts claim that

Tire Safety

after five years, trailer tires are considered worn out and should be replaced, even if they have had minimal or no use. This is such a general statement that it may not apply in all cases. It is best to have your tires inspected by a tire supplier to determine if your tires need to be replaced.

If you are storing your trailer for an extended period, make sure the tires are fully inflated to the maximum rated pressure and that you store them in a cool, dry place, such as a garage. Use tire covers to protect the trailer tires from the harsh effects of the sun.

3.2 Steps For Determining Correct Load Limit - Trailer

Determining the load limits of a trailer includes more than understanding the load limits of the tires alone. On all trailers there is a Federal Certification / VIN label that is located on the forward half of the left (road) side of the unit. This certification/VIN label will indicate the trailer's Gross Vehicle Weight Rating (GVWR). This is the most weight the fully loaded trailer can weigh. It will also provide the Gross Axle Weight Rating (GAWR). This is the most a particular axle can weigh. If there are multiple axles, the GAWR of each axle will be provided.

If your trailer has a GVWR of 10,000 pounds or less, there is a vehicle placard located in the same location as the certification label described above. This placard provides tire and loading information. In addition, this placard will show a statement regarding maximum cargo capacity.

Cargo can be added to the trailer, up to the maximum weight specified on the placard. The combined weight of the cargo is provided as a single number. In any case, remember: the total weight of a fully loaded trailer can not exceed the stated GVWR.

When loading your cargo, be sure it is distributed evenly to prevent overloading front to back and side to side. Heavy items should be placed low and as close to the axle positions as reasonable. Too many items on one side may overload a tire. The best way to know the actual weight of the vehicle is to weigh it at a public scale. Talk to your dealer to discuss the weighing methods needed to capture the various weights related to the trailer. This would include the weight empty or unloaded, weights per axle, wheel, hitch or king-pin, and total weight.

Excessive loads and/or under inflation cause tire overloading and, as a result, abnormal tire flexing

occurs. This situation can generate an excessive amount of heat within the tire. Excessive heat may lead to tire failure. It is the air pressure that enables a tire to support the load, so proper inflation is critical. The proper air pressure may be found on the Certification / VIN label and/or on the Tire Placard. This value should never exceed the maximum cold inflation pressure stamped on the tire.

3.2.1 Trailers 10,000 Pounds GVWR Or Less

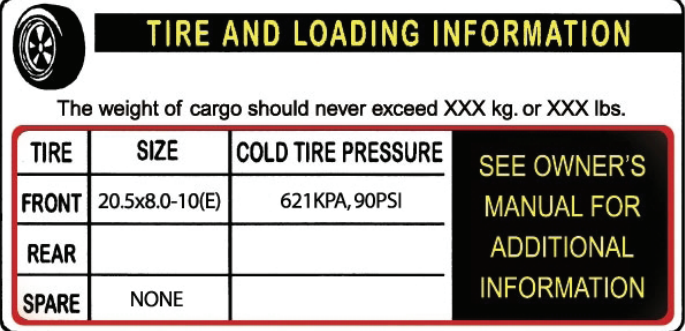

The weight of cargo should never exceed XXX kg. or XXX lbs.

TIRE	SIZE	COLD TIRE PRESSURE
FRONT	20.5x8.0-10(E)	621KPA, 90PSI
REAR		
SPARE	NONE	

SEE OWNER'S MANUAL FOR ADDITIONAL INFORMATION

1. Locate the statement, "The weight of cargo should never exceed XXX kg or XXX lbs.," on your vehicle's placard.
2. This figure equals the available amount of cargo and luggage load capacity.
3. Determine the combined weight of luggage and cargo being loaded on the vehicle. That weight may not safely exceed the available cargo and luggage load capacity.
4. The trailer's placard refers to the Tire Information Placard attached adjacent to or near the trailer's VIN (Certification) label at the left front of the trailer.

3.2.2 Trailers Over 10,000 Pounds GVWR

(Note: These trailers are not required to have a tire information placard on the trailer and may not have one installed)

1. Determine the empty weight of your trailer by weighing the trailer using a public scale or other means.
2. Locate the GVWR (Gross Vehicle Weight Rating) of the trailer on your trailer's VIN (Certification) label.
3. Subtract the empty weight of your trailer from the GVWR stated on the VIN label. That weight is the maximum available cargo capacity of the trailer and may not be safely exceeded. National Highway Transportation Safety Administration (NHTSA) in addition to notifying us.

3.3 Steps For Determining Correct Load Limit - Tow Vehicle

1. Locate the statement, "The combined weight of occupants and cargo should never exceed XXX lbs.," on your vehicle's placard.
2. Determine the combined weight of the driver and passengers who will be riding in your vehicle.
3. Subtract the combined weight of the driver and passengers from XXX kilograms or XXX pounds.
4. The resulting figure equals the available amount of cargo and luggage capacity. For example, if the "XXX" amount equals 1400 lbs. and there will be five 150 lb. passengers in your vehicle, the amount of available cargo and luggage capacity is 650 lbs. (1400-750 (5 x 150) = 650 lbs.).
5. Determine the combined weight of luggage and cargo being loaded on the vehicle. That weight may not safely exceed the available cargo and luggage capacity calculated in previous step.
6. If your vehicle will be towing a trailer, load from your trailer will be transferred to your vehicle. Consult the tow vehicle's manual to determine how this weight transfer reduces the available cargo and luggage capacity of your vehicle.

3.4 Glossary Of Tire Terminology

Accessory weight: The combined weight (in excess of those standard items which may be replaced) of automatic transmission, power steering, power brakes, power windows, power seats, radio and heater, to the extent that these items are available as factory-installed equipment (whether installed or not).

Bead: The part of the tire that is made of steel wires, wrapped or reinforced by ply cords and that is shaped to fit the rim.

Bead separation: This is the breakdown of the bond between components in the bead.

Bias ply tire: A pneumatic tire in which the ply cords that extend to the beads are laid at alternate angles substantially less than 90 degrees to the centerline of the tread.

Carcass: The tire structure, except tread and sidewall rubber which, when inflated, bears the load.

Chunking: The breaking away of pieces of the tread or sidewall.

Cold inflation pressure: The pressure in the tire before you drive.

Cord: The strands forming the plies in the tire.

Cord separation: The parting of cords from adjacent rubber compounds.

Cracking: Any parting within the tread, sidewall, or inner liner of the tire extending to cord material.

CT: A pneumatic tire with an inverted flange tire and rim system in which the rim is designed with rim flanges pointed radially inward and the tire is designed to fit on the underside of the rim in a manner that encloses the rim flanges inside the air cavity of the tire.

Curb weight: The weight of a motor vehicle with standard equipment including the maximum capacity of fuel, oil, and coolant, and, if so equipped, air conditioning and additional weight optional engine.

Extra load tire: A tire designed to operate at higher loads and at higher inflation pressures than the corresponding standard tire.

Groove: The space between two adjacent tread ribs.

Gross Axle Weight Rating: The maximum weight that any axle can support, as published on the Certification / VIN label on the front left side of the trailer. Actual weight determined by weighing each axle on a public scale, with the trailer attached to the towing vehicle.

Gross Vehicle Weight Rating: The maximum weight of the fully loaded trailer, as published on the Certification / VIN label. Actual weight determined by weighing trailer on a public scale, without being attached to the towing vehicle.

Hitch Weight: The downward force exerted on the hitch ball by the trailer coupler.

Innerliner: The layer(s) forming the inside surface of a tubeless tire that contains the inflating medium within the tire.

Innerliner separation: The parting of the innerliner from cord material in the carcass.

Intended outboard sidewall: The sidewall that contains a white-wall, bears white lettering or bears manufacturer, brand, and/or model name molding that

Tire Safety

is higher or deeper than the same molding on the other sidewall of the tire or the outward facing sidewall of an asymmetrical tire that has a particular side that must always face outward when mounted on a vehicle.

Light truck (LT) tire: A tire designated by its manufacturer as primarily intended for use on lightweight trucks or multipurpose passenger vehicles. May be used on trailers.

Load rating: The maximum load that a tire is rated to carry for a given inflation pressure.

Maximum load rating: The load rating for a tire at the maximum permissible inflation pressure for that tire.

Maximum permissible inflation pressure: The maximum cold inflation pressure to which a tire may be inflated.

Maximum loaded vehicle weight: The sum of curb weight, accessory weight, vehicle capacity weight, and production options weight.

Measuring rim: The rim on which a tire is fitted for physical dimension requirements.

Non-pneumatic rim: A mechanical device which, when a non-pneumatic tire assembly incorporates a wheel, supports the tire, and attaches, either integrally or separably, to the wheel center member and upon which the tire is attached.

Non-pneumatic spare tire assembly: A non-pneumatic tire assembly intended for temporary use in place of one of the pneumatic tires and rims that are fitted to a passenger car in compliance with the requirements of this standard.

Non-pneumatic tire: A mechanical device which transmits, either directly or through a wheel or wheel center member, the vertical load and tractive forces from the roadway to the vehicle, generates the tractive forces that provide the directional control of the vehicle and does not rely on the containment of any gas or fluid for providing those functions.

Non-pneumatic tire assembly: A non-pneumatic tire, alone or in combination with a wheel or wheel center member, which can be mounted on a vehicle.

Normal occupant weight: This means 68 kilograms (150 lbs.) times the number of occupants specified in the second column of Table I of 49 CFR 571.110.

Occupant distribution: The distribution of occupants in a vehicle as specified in the third column of Table I of 49 CFR 571.110.

Open splice: Any parting at any junction of tread, sidewall, or innerliner that extends to cord material.

Outer diameter: The overall diameter of an inflated new tire.

Overall width: The linear distance between the exteriors of the sidewalls of an inflated tire, including elevations due to labeling, decorations, or protective bands or ribs.

Pin Weight: The downward force applied to the 5th wheel or gooseneck ball, by the trailer kingpin or gooseneck coupler.

Ply: A layer of rubber-coated parallel cords.

Ply separation: A parting of rubber compound between adjacent plies.

Pneumatic tire: A mechanical device made of rubber, chemicals, fabric and steel or other materials, that, when mounted on an automotive wheel, provides the traction and contains the gas or fluid that sustains the load.

Production options weight: The combined weight of those installed regular production options weighing over 2.3 kilograms (5 lbs.) in excess of those standard items which they replace, not previously considered in curb weight or accessory weight, including heavy duty brakes, ride levelers, roof rack, heavy duty battery, and special trim.

Radial ply tire: A pneumatic tire in which the ply cords that extend to the beads are laid at substantially 90 degrees to the centerline of the tread.

Recommended inflation pressure: This is the inflation pressure provided by the vehicle manufacturer on the Tire Information label and on the Certification / VIN tag.

Reinforced tire: A tire designed to operate at higher loads and at higher inflation pressures than the corresponding standard tire.

Rim: A metal support for a tire or a tire and tube assembly upon which the tire beads are seated.

Rim diameter: This means the nominal diameter of the bead seat.

Rim size designation: This means the rim diameter and width.

Rim type designation: This means the industry of manufacturer's designation for a rim by style or code.

Rim width: This means the nominal distance between rim flanges.

Section width: The linear distance between the exteriors of the sidewalls of an inflated tire, excluding elevations due to labeling, decoration, or protective bands.

Sidewall: That portion of a tire between the tread and bead.

Sidewall separation: The parting of the rubber compound from the cord material in the sidewall.

Special Trailer (ST) tire: The "ST" is an indication the tire is for trailer use only.

Test rim: The rim on which a tire is fitted for testing, and may be any rim listed as appropriate for use with that tire.

Tread: That portion of a tire that comes into contact with the road.

Tread rib: A tread section running circumferentially around a tire.

Tread separation: Pulling away of the tread from the tire carcass.

Treadwear indicators (TWI): The projections within the principal grooves designed to give a visual indication of the degrees of wear of the tread.

Vehicle capacity weight: The rated cargo and luggage load plus 68 kilograms (150 lbs.) times the vehicle's designated seating capacity.

Vehicle maximum load on the tire: The load on an individual tire that is determined by distributing to each axle its share of the maximum loaded vehicle weight and dividing by two.

Vehicle normal load on the tire: The load on an

individual tire that is determined by distributing to each axle its share of the curb weight, accessory weight, and normal occupant weight (distributed in accordance with Table I of CRF 49 571.110) and dividing by 2.

Weather side: The surface area of the rim not covered by the inflated tire.

Wheel center member: In the case of a non-pneumatic tire assembly incorporating a wheel, a mechanical device which attaches, either integrally or separably, to the non-pneumatic rim and provides the connection between the nonpneumatic rim and the vehicle; or, in the case of a non-pneumatic tire assembly not incorporating a wheel, a mechanical device which attaches, either integrally or separably, to the non-pneumatic tire and provides the connection between tire and the vehicle.

Wheel-holding fixture: The fixture used to hold the wheel and tire assembly securely during testing.

3.5 Tire Safety - Everything Rides On It

The National Traffic Safety Administration (NHTSA) has published a brochure (DOT HS 809 361) that discusses all aspects of Tire Safety, as required by CFR 575.6. This brochure is reproduced in part below. It can be obtained and downloaded from NHTSA, free of charge, from the following web site:

<https://www.nhtsa.gov/equipment/tires>

Studies of tire safety show that maintaining proper tire pressure, observing tire and vehicle load limits (not carrying more weight in your vehicle than your tires or vehicle can safely handle), avoiding road hazards, and inspecting tires for cuts, slashes, and other irregularities are the most important things you can do to avoid tire failure, such as tread separation or blowout and flat tires. These actions, along with other care and maintenance activities, can also:

- Improve vehicle handling
- Help protect you and others from avoidable breakdowns and accidents
- Improve fuel economy
- Increase the life of your tires.

This booklet presents a comprehensive overview of tire safety, including information on the following topics:

- Basic tire maintenance
- Uniform Tire Quality Grading System
- Fundamental characteristics of tires
- Tire safety tips.

Use this information to make tire safety a regular part of your vehicle maintenance routine. Recognize that the time you spend is minimal compared with the inconvenience and safety consequences of a flat tire or other tire failure.

3.5.1 Safety First - Basic Tire Maintenance

Properly maintained tires improve the steering, stopping, traction, and load-carrying capability of your vehicle. Underinflated tires and overloaded vehicles are a major cause of tire failure. Therefore, as mentioned above, to avoid flat tires and other types of tire failure, you should maintain proper tire pressure, observe tire and vehicle load limits, avoid road hazards, and regularly inspect your tires.

3.5.2 Finding Your Vehicle's Recommended Tire Pressure And Load Limits

Tire information placards and vehicle certification labels contain information on tires and load limits. These labels indicate the vehicle manufacturer's information including:

- Recommended tire size
- Recommended tire inflation pressure
- Vehicle capacity weight (VCW—the maximum occupant and cargo weight a vehicle is designed to carry)
- Front and rear gross axle weight ratings (GAWR—the maximum weight the axle systems are designed to carry).
- Both placards and certification labels are permanently attached to the trailer near the left front.

3.5.3 Understanding Tire Pressure And Load Limits

Tire inflation pressure is the level of air in the tire that provides it with load-carrying capacity and affects the overall performance of the vehicle. The tire inflation pressure is a number that indicates the amount of air pressure—measured in pounds per square inch (psi)—a tire requires to be properly inflated. (You will also find this number on the vehicle information placard expressed in kilopascals (kPa), which is the metric measure used internationally.)

Manufacturers of passenger vehicles and light trucks determine this number based on the vehicle's design load limit, that is, the greatest amount of weight a vehicle can safely carry and the vehicle's tire size. The proper tire pressure for your vehicle is referred to as the "recommended cold inflation pressure." (As you will read below, it is difficult to obtain the recommended tire pressure if your tires are not cold.)

Because tires are designed to be used on more than one type of vehicle, tire manufacturers list the "maximum permissible inflation pressure" on the tire sidewall. This number is the greatest amount of air pressure that should ever be put in the tire under normal driving conditions.

3.5.4 Safety First - Basic Tire Maintenance

It is important to check your vehicle's tire pressure at least once a month for the following reasons:

- Most tires may naturally lose air over time.
- Tires can lose air suddenly if you drive over a pothole or other object or if you strike the curb when parking.
- With radial tires, it is usually not possible to determine under inflation by visual inspection.

For convenience, purchase a tire pressure gauge to keep in your vehicle. Gauges can be purchased at tire dealerships, auto supply stores, and other retail outlets. The recommended tire inflation pressure that vehicle manufacturers provide reflects the proper psi when a tire is cold. The term cold does not relate to the outside temperature. Rather, a cold tire is one that has not been driven on for at least three hours. When you drive, your tires get warmer, causing the air pressure within them to increase. Therefore, to get an accurate tire pressure reading, you must measure tire pressure when the tires are cold or compensate for the extra pressure in warm tires.

3.5.5 Steps For Maintaining Proper Tire Pressure

1. Locate the recommended tire pressure on the vehicle's tire information placard, certification label, or in the owner's manual.
2. Record the tire pressure of all tires.
3. If the tire pressure is too high in any of the tires, slowly release air by gently pressing on the tire valve stem with the edge of your tire gauge until you get to the correct pressure.
4. If the tire pressure is too low, note the difference

Tire Safety

between the measured tire pressure and the correct tire pressure. These “missing” pounds of pressure are what you will need to add.

5. At a service station, add the missing pounds of air pressure to each tire that is under inflated.
6. Check all the tires to make sure they have the same air pressure except in cases in which the front and rear tires are supposed to have different amounts of pressure).

If you have been driving your vehicle and think that a tire is under inflated, fill it to the recommended cold inflation pressure indicated on your vehicle’s tire information placard or certification label. While your tire may still be slightly under inflated due to the extra pounds of pressure in the warm tire, it is safer to drive with air pressure that is slightly lower than the vehicle manufacturer’s recommended cold inflation pressure than to drive with a significantly under inflated tire. Since this is a temporary fix, don’t forget to recheck and adjust the tire’s pressure when you can obtain a cold reading.

3.5.6 Tire Size

To maintain tire safety, purchase new tires that are the same size as the vehicle’s original tires or another size recommended by the manufacturer. Look at the tire information placard, the owner’s manual, or the sidewall of the tire you are replacing to find this information. If you have any doubt about the correct size to choose, consult with the tire dealer.

3.5.7 Tire Tread

The tire tread provides the gripping action and traction that prevent your vehicle from slipping or sliding, especially when the road is wet or icy. In general, tires are not safe and should be replaced when the tread is worn down to 2/32 of an inch. Tires have built-in tread wear indicators that let you know when it is time to replace your tires. These indicators are raised sections spaced intermittently in the bottom of the tread grooves. When they appear “even” with the outside of the tread, it is time to replace your tires. Another method for checking tread depth is to place a penny in the tread with Lincoln’s head upside down and facing you. If you can see the top of Lincoln’s head, you are ready for new tires.

3.5.8 Tire Balance And Wheel Alignment

To avoid vibration or shaking of the vehicle when a tire rotates, the tire must be properly balanced. This balance is achieved by positioning weights on the wheel

to counterbalance heavy spots on the wheel-and-tire assembly. A wheel alignment adjusts the angles of the wheels so that they are positioned correctly relative to the vehicle’s frame. This adjustment maximizes the life of your tires. These adjustments require special equipment and should be performed by a qualified technician.

3.5.9 Tire Repair

The proper repair of a punctured tire requires a plug for the hole and a patch for the area inside the tire that surrounds the puncture hole. Punctures through the tread can be repaired if they are not too large, but punctures to the sidewall should not be repaired. Tires must be removed from the rim to be properly inspected before being plugged and patched.

3.5.10 Tire Fundamentals

Federal law requires tire manufacturers to place standardized information on the sidewall of all tires. This information identifies and describes the fundamental characteristics of the tire and also provides a tire identification number for safety standard certification and in case of a recall.

3.5.10.1 Information on Passenger Vehicle Tires

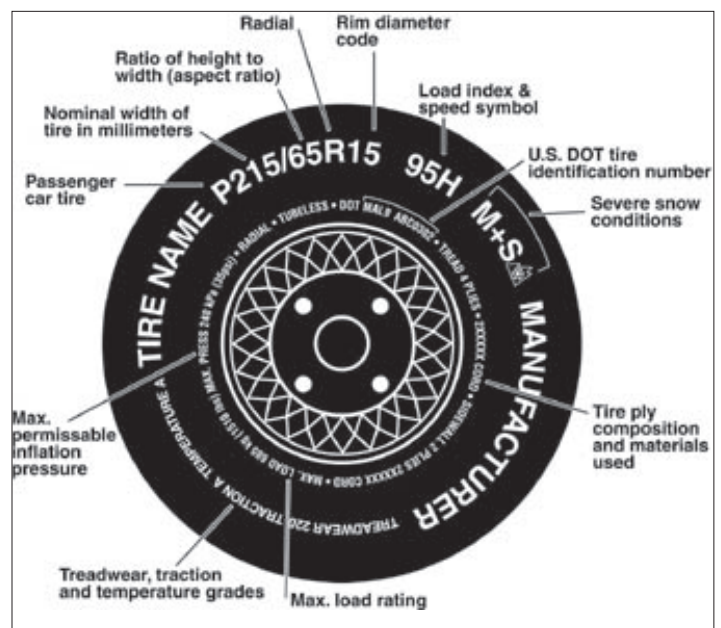

P: The “P” indicates the tire is for passenger vehicles.

Next number: This three-digit number gives the width in millimeters of the tire from sidewall edge to sidewall edge. In general, the larger the number, the wider the tire.

Tire Safety

Next number: This two-digit number, known as the aspect ratio, gives the tire's ratio of height to width. Numbers of 70 or lower indicate a short sidewall for improved steering response and better overall handling on dry pavement.

R: The "R" stands for radial. Radial ply construction of tires has been the industry standard for the past 20 years.

Next number: This two-digit number is the wheel or rim diameter in inches. If you change your wheel size, you will have to purchase new tires to match the new wheel diameter.

Next number: This two- or three-digit number is the tire's load index. It is a measurement of how much weight each tire can support. You may find this information in your owner's manual. If not, contact a local tire dealer. Note: You may not find this information on all tires because it is not required by law.

M+S: The "M+S" or "M/S" indicates that the tire has some mud and snow capability. Most radial tires have these markings; hence, they have some mud and snow capability.

Speed Rating: The speed rating denotes the speed at which a tire is designed to be driven for extended periods of time.

Note: You may not find this information on all tires because it is not required by law.

U.S. DOT Tire Identification Number: This begins with the letters "DOT" and indicates that the tire meets all federal standards. The next two numbers or letters are the plant code where it was manufactured, and the last four numbers represent the week and year the tire was built. For example, the numbers 3197 means the 31st week of 1997. The other numbers are marketing codes used at the manufacturer's discretion. This information is used to contact consumers if a tire defect requires a recall.

Tire Ply Composition and Materials Used: The number of plies indicates the number of layers of rubber-coated fabric in the tire. In general, the greater the number of plies, the more weight a tire can support. Tire manufacturers also must indicate the materials in the tire, which include steel, nylon, polyester, and others.

Maximum Load Rating: This number indicates the maximum load in kilograms and pounds that can be carried by the tire.

Maximum Permissible Inflation Pressure: This number is the greatest amount of air pressure that should ever be put in the tire under normal driving conditions.

3.5.10.2 UTQGS Information

Treadwear Number: This number indicates the tire's wear rate. The higher the treadwear number is, the longer it should take for the tread to wear down. For example, a tire graded 400 should last twice as long as a tire graded 200.

Traction Letter: This letter indicates a tire's ability to stop on wet pavement. A higher graded tire should allow you to stop your car on wet roads in a shorter distance than a tire with a lower grade. Traction is graded from highest to lowest as "AA", "A", "B", and "C".

Temperature Letter: This letter indicates a tire's resistance to heat. The temperature grade is for a tire that is inflated properly and not overloaded. Excessive speed, under inflation or excessive loading, either separately or in combination, can cause heat build-up and possible tire failure. From highest to lowest, a tire's resistance to heat is graded as "A", "B", or "C".

3.5.10.3 Additional Information On Light Truck Tires

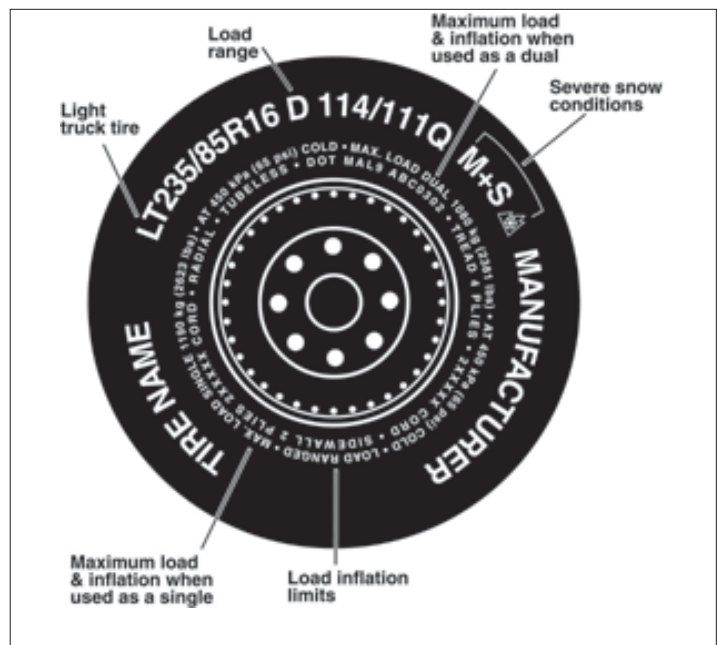

Tires for light trucks have other markings besides those

found on the sidewalls of passenger tires.

LT: The “LT” indicates the tire is for light trucks or trailers.

ST: An “ST” is an indication the tire is for trailer use only.

Max. Load Dual kg (lbs) at kPa (psi) Cold: This information indicates the maximum load and tire pressure when the tire is used as a dual, that is, when four tires are put on each rear axle (a total of six or more tires on the vehicle).

Max. Load Single kg (lbs) at kPa (psi) Cold: This information indicates the maximum load and tire pressure when the tire is used as a single.

Load Range: This information identifies the tire’s load-carrying capabilities and its inflation limits.

3.5.10.4 Tire Safety Tips

Preventing Tire Damage

- Slow down if you have to go over a pothole or other object in the road.
- Do not run over curbs or other foreign objects in the roadway, and try not to strike the curb when parking.

Tire Safety Checklist

- Check tire pressure regularly (at least once a month), including the spare.
- Inspect tires for uneven wear patterns on the tread, cracks, foreign objects, or other signs of wear or trauma.
- Remove bits of glass and foreign objects wedged in the tread.
- Make sure your tire valves have valve caps.
- Check tire pressure before going on a long trip.
- Do not overload your vehicle. Check the Tire Information Placard or Owner’s Manual for the maximum recommended load for the vehicle.

4. Coupling To Tow Vehicle

Follow all of the safety precautions and instructions in this manual to ensure safety of persons, cargo, and satisfactory life of the trailer.

4.1 Tow Vehicle And Hitch

If the vehicle and hitch are not properly selected and matched to the Gross Vehicle Weight Rating (GVWR) of your trailer, you can cause an accident that could lead to death or serious injury. If you already have a tow vehicle, know your vehicle tow rating and make certain the trailer's rated capacity is less than or equal to the tow vehicle's rated towing capacity.

DANGER

Use of a tow vehicle with a towing capacity less than the load rating of the trailer can result in loss of control, and may lead to death or serious injury.

Use of a hitch with a load rating less than the load rating of the trailer can result in loss of control and may lead to death or serious injury.

Verify hitch and tow vehicle are rated for the Gross Vehicle Weight Rating of your trailer.

4.1.1 Trailer Information

The Certification / Vehicle Identification Number (VIN) tag is located on the front left side of the trailer.

The trailer Certification / VIN tag contains the following critical safety information for the use of your trailer:

MANUFACTURER: Name of trailer manufacturer.

DATE OF MANUFACTURE: Month and year the trailer was manufactured.

GVWR: The Gross Vehicle Weight Rating is the maximum allowable gross weight of the trailer and its contents. The gross weight of the trailer includes the weight of the trailer and all of the items within it (such as cargo and other supplies).

GAWR: The Gross Axle Weight Rating is the maximum gross weight that an axle can support. It is the lowest of

axle, wheel, or tire rating. Sometimes the tire or wheel rating is lower than the axle manufacturers rating, and will then determine GAWR.

The sum total of the GAWR for all trailer axles may be less than the GVWR for the trailer, because some of the trailer load is carried by the tow vehicle, rather than by the trailer axle(s). The total weight of the cargo and trailer must not exceed the GVWR, and the load on an axle must not exceed its GAWR.

TIRE SIZE: The tire size and load range for your trailer.

RIM SIZE: The rim size and load range for your trailer.

PSI: The tire air pressure (kPa / PSI) measured with tires cold.

VIN: The Vehicle Identification Number.

VEHICLE TYPE: Model or style of trailer.

CERTIFICATION STATEMENT: "This trailer meets all the Federal Motor Vehicle Safety Standards in effect on the date of manufacture shown above".

4.1.2 Tow Vehicle

When equipping a new vehicle or an older vehicle to tow a trailer, ask the vehicle dealer for advice on how to outfit the tow vehicle.

Vehicle manufacturers will provide you with the maximum towing capacities of their various models, as well as the GCWR. No amount of reinforcement will give a 100 horsepower, 2,500 pound truck the towing capacity that a 300 horsepower, 5,000 pound truck has.

4.2 Coupling And Uncoupling The Trailer

A secure coupling (or fastening) of the trailer to the tow vehicle is essential. A loss of coupling may result in death or serious injury. Therefore, you must understand and follow all of the instructions for coupling.

The following parts are involved in making a secure coupling between the trailer and tow vehicle:

Coupling: The trailer connecting mechanism by which the connection is actually made to the trailer hitch. This does not include any structural member, extension of the trailer frame, or brake controller.

Coupling To Tow Vehicle

Hitch: The connecting mechanism including the ball support platform and ball and those components that extend and are attached to the towing vehicle, including bumpers intended to serve as hitches.

Safety chains: Chains permanently attached to the trailer such that if the coupler connection comes loose, the safety chains can keep the trailer attached to the tow vehicle. With properly rigged safety chains, it is possible to keep the tongue of the trailer from digging into the road pavement, even if the coupler-to-hitch connection comes apart.

Trailer lighting (and braking) connector: A device that connects electrical power from the tow vehicle to the trailer. In addition, if your trailer has a separate braking system, the electrical connector will also supply power to the trailer brakes from the tow vehicle.

Breakaway switch: If the trailer becomes uncoupled from the tow vehicle, the breakaway switch lanyard, attached independently to the tow vehicle hitch, will pull a pin in the emergency electrical breakaway switch on the trailer. The breakaway switch is activated by a battery on the trailer to energize the trailer brakes independently of the towing vehicle.

It is important to check the state of charge of the emergency breakaway battery before each trip. Simply pull the pin out of the switch by hand and then try to pull the trailer. If you feel a significant drag force the brakes are activated. Be sure to re-insert the pin in the breakaway switch. Also be sure to allow enough slack in the breakaway brake lanyard such that the switch will only activate (pin pulls out) if the coupler connection comes loose.

Jack: A device on the trailer that is used to raise and lower the trailer tongue.



WARNING

An improperly coupled trailer can result in death or serious injury. Do not move the trailer until:

- **Coupler is secured and locked to hitch.**
- **Safety chains are secured to tow vehicle.**
- **Trailer jack(s) are fully retracted.**
- **Trailer brakes are checked.**
- **Tires and wheels are checked.**
- **Breakaway switch is connected to tow vehicle;**
- **The trailer lights are connected and checked.**
- **Load is secured to trailer.**

4.3 Couple Trailer To Tow Vehicle

The trailer may be equipped with a ball hitch coupler or a ring & pintle coupler. See the appropriate section for the coupler on your trailer.

4.3.1 Ball Hitch Coupler

A ball hitch coupler connects to a ball that is located on or under the rear bumper of tow vehicle.

We have utilized a ball hitch coupler that is suitable for the size and weight of the trailer. The load rating of the coupler and the necessary ball size are listed on the trailer tongue.

You must provide a hitch and ball for your tow vehicle, that meets or exceeds the GVWR of the trailer.

The ball size must be the same as the coupler size. If the hitch ball is too small, too large, is underrated, is loose or is worn, the trailer can come loose from the tow vehicle, and may cause death or serious injury.

The tow vehicle, hitch and ball must have a rated towing capacity equal to or greater than the trailer gross vehicle weight rating (GVWR).

It is essential that the hitch ball be the same size as the coupler.

The ball size and load rating (capacity) are marked on the ball; hitch capacity is marked on the hitch.

Coupling To Tow Vehicle

4.3.1.1 Before Coupling Trailer To Tow Vehicle

1. Be sure the size and rating of hitch ball match the size and rating of the coupler. Hitch balls and couplers are marked with their size and rating.

WARNING

Coupler-to-hitch mismatch can result in uncoupling, leading to death or serious injury.

Be sure the LOAD RATING of the hitch ball is equal or greater than the load rating of the coupler.

Be sure the SIZE of the hitch ball matches the size of the coupler.

2. Wipe the hitch ball clean and inspect it visually and by feel for flat spots, cracks and pits.

WARNING

A worn, cracked or corroded hitch ball can fail while towing, and may result in death or serious injury.

Before coupling trailer, inspect the hitch ball for wear, corrosion and cracks.

Replace worn or damaged hitch ball.

3. Rock the ball to make sure it is tight to the hitch, and visually check that the hitch ball nut is solid against the lock washer and hitch frame.
4. Wipe the inside and outside of the coupler clean and inspect it visually for cracks and deformations; feel the inside of the coupler for worn spots and pits.
5. Be sure the coupler is tight to the tongue of the trailer. All coupler fasteners must be visibly solid against the trailer frame.

WARNING

A loose hitch ball nut can result in uncoupling, leading to death or serious injury.

Make sure the hitch ball is tight to the hitch before coupling the trailer.

6. Raise the bottom surface of the coupler to be above the top of the hitch ball.

4.3.1.2 Prepare Coupler And Hitch

1. Lubricate hitch ball and inside of coupler with a thin layer of automotive bearing grease.
2. Remove safety latch pin and open coupler locking mechanism. In the open position, coupler is able to drop fully onto hitch ball. See the coupler instructions for details of placing the coupler in the "open" position.
3. Slowly back up tow vehicle so that hitch ball is near or aligned under coupler.

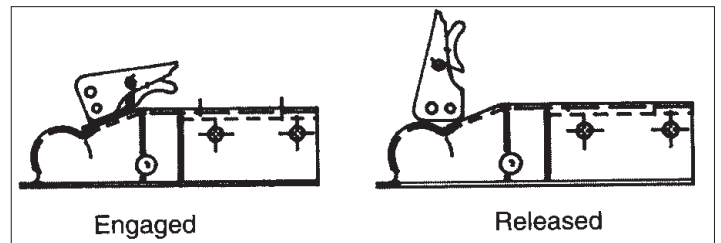

Your trailer may be equipped with a different style coupler. If so, see the coupler manufacturers operating instructions.

4.3.1.3 Couple Trailer To Tow Vehicle

1. Lower the trailer tongue until the coupler fully engages the hitch ball. If the coupler does not line up with the hitch ball, adjust the position of the tow vehicle.
2. Close latch and engage the coupler locking mechanism. In the engaged position, the locking mechanism securely holds the coupler to the hitch ball.
3. Insert the safety lock pin through the hole in the locking mechanism.
4. Be sure the coupler is all the way on the hitch ball and the locking mechanism is engaged. A properly engaged locking mechanism will allow the coupler to raise the rear of the tow vehicle. Using the trailer jack, test to see that you can raise the rear of the tow vehicle by 1 inch, after the coupler is locked to the hitch.

NOTICE

The tongue jack can be damaged by overloading. Do not use the tongue jack to raise the tow vehicle more than 1 inch.

5. If the coupler cannot be secured to the hitch ball, do not tow the trailer. Contact your dealer for assistance.
6. Lower the trailer so that its entire tongue weight is held by the hitch, and continue retracting the jack to its fully retracted position.

CAUTION

Drop leg jacks may be spring loaded and may rapidly return to the raise position when released.

Keep clear when releasing drop legs.

7. Fully retract jack drop leg if equipped.

Go to Section 4.3.3 “Connect Safety Chains” to continue connecting trailer to tow vehicle.

4.3.2 Trailer With Ring And Pintle Coupler

A ring on the trailer connects to the pintle that is located on or under the rear bumper of tow vehicle.

We have utilized a ring that is suitable for the size and weight of the trailer. The load rating of the ring and the necessary pintle size are listed on the trailer tongue.

You must provide a pintle for your tow vehicle, where the load rating of the hitch and pintle is equal to or greater than that of your trailer. The pintle size must be the same as the ring size. If the pintle is too small, too large, is underrated, is loose or is worn, the trailer can come loose from the tow vehicle, and may cause death or serious injury.

The tow vehicle, hitch and pintle must have a rated towing capacity equal to or greater than the trailer gross vehicle weight rating (GVWR).

It is essential that the pintle be the same size as the coupler.

The pintle size and load rating (capacity) are marked on the pintle; ring capacity is marked on the ring.

4.3.2.1 Before Coupling Trailer To Tow Vehicle

1. Be sure the size and rating of pintle match the size and rating of the ring. Hitch ring and pintles are marked with their size and rating.

WARNING

Ring-to-pintle mismatch can result in uncoupling, leading to death or serious injury.

Be sure the LOAD RATING of the pintle is equal or greater than the load rating of the ring.

Be sure the SIZE of the pintle matches the size of the ring.

2. Wipe the pintle clean and inspect it visually and by feel for flat spots, cracks and pits.

WARNING

A worn, cracked or corroded pintle can fail while towing, and may result in death or serious injury.

Before coupling trailer, inspect the pintle for wear, corrosion and cracks. Replace worn or damaged pintle.

3. Rock the pintle to make sure it is tight to the hitch, and visually check that the pintle fasteners are solid against the hitch frame.
4. Wipe the inside and outside of the ring clean and inspect it visually for cracks and deformations; feel the inside of the ring for worn spots and pits.
5. Be sure the ring is tight to the tongue of the trailer. All ring fasteners must be visibly solid against the trailer frame.

Coupling To Tow Vehicle

WARNING

A loose pintle can result in uncoupling, leading to death or serious injury.

Make sure the pintle is tight to the hitch before coupling the trailer.

6. Raise the bottom surface of the ring to be above the top of the open pintle.

4.3.2.2 Prepare Ring And Pintle

1. Lubricate the inside of the pintle with a thin layer of automotive bearing grease.
2. Remove the safety latch pin and open the pintle locking mechanism.
3. In the open position, the ring is able to drop fully onto the pintle.

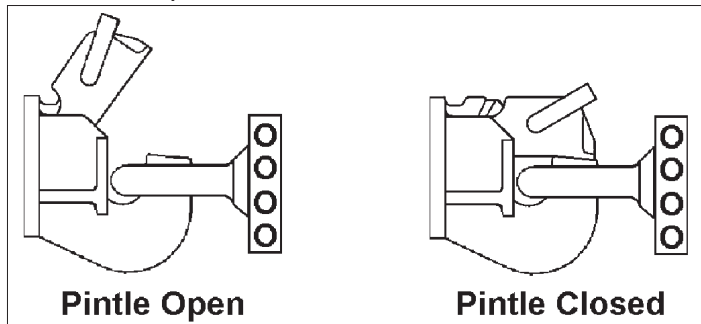

4. See the coupler instructions for details of placing the pintle in the “open” position.
5. Slowly back up the tow vehicle so that the pintle is aligned under the ring.

4.3.2.3 Couple Trailer To Tow Vehicle

1. Lower the trailer tongue until the ring fully engages the pintle. If the ring does not line up with the pintle, adjust the position of the tow vehicle.
2. Close pintle and engage the pintle locking mechanism. In the engaged position, the locking mechanism securely holds the ring to the pintle.
3. Insert the safety lock pin through the hole in the locking mechanism.
4. Be sure the ring is all the way on the pintle and the locking mechanism is engaged. A properly engaged locking mechanism will allow the pintle to raise the rear of the tow vehicle. Using the trailer jack, test to see that you can raise the rear of the tow vehicle by 1 inch, after the pintle is closed and locked.

NOTICE

The tongue jack can be damaged by overloading. Do not use the tongue jack to raise the tow vehicle more than 1 inch.

5. If the ring cannot be secured to the pintle, do not tow the trailer. Contact your dealer for assistance.
6. Lower the trailer so that its entire tongue weight is held by the hitch, and continue retracting the jack to its fully retracted position.

CAUTION

Drop leg jacks may be spring loaded and may rapidly return to the raise position when released.

Keep clear when releasing drop legs.

7. Fully retract jack drop leg if equipped.

Go to Section 4.3.3 “Connect Safety Chains” to continue connecting trailer to tow vehicle.

4.3.3 Connect Safety Chains

1. Visually inspect the safety chains and hooks for wear or damage. Replace worn or damaged safety chains and hooks before towing.
2. Safety chains must crisscross under the coupler so if the trailer uncouples, the safety chains can hold the tongue up above the road. Loop around a frame member of the tow vehicle or to holes provided in the hitch system, but do not attach them to an interchangeable part of the hitch assembly.
3. Attach hooks up from underneath the hole. Do not just drop into hole.
4. Provide enough slack in chains to permit tight turns, but not be close to the road surface to drag.

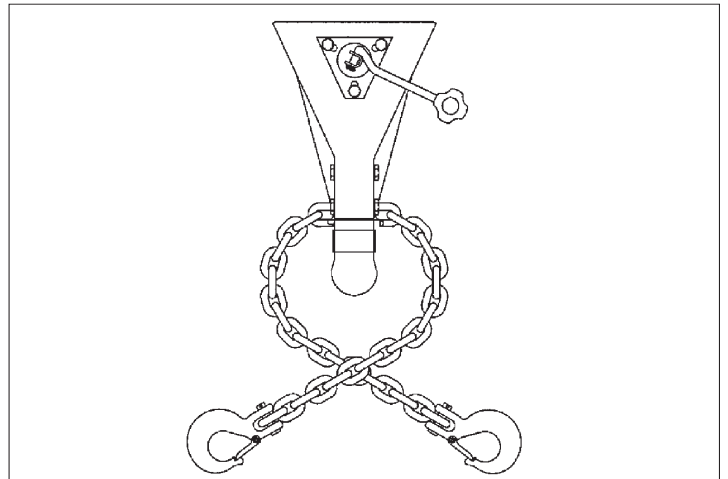

Coupling To Tow Vehicle

WARNING

Improper rigging of the safety chains can result in loss of control of the trailer and tow vehicle, leading to death or serious injury, if the trailer uncouples from the tow vehicle.

Cross chains underneath hitch and coupler with enough slack to permit turning and to hold tongue up, if the trailer comes loose.

Fasten chains to frame of tow vehicle.

Do not fasten chains to any part of the hitch unless the hitch has holes or loops specifically for that purpose.

4.3.4 Connect Electrical Cable

1. Connect the trailer lights to the tow vehicle's electrical system using trailer electrical cable.
2. Check all lights for proper operation. Repair or replace non-working lights before towing trailer.
3. Check electric brakes for proper operation using brake controller mounted in the cab.

WARNING

Improper electrical connection between the tow vehicle and the trailer will result in inoperable lights and electric brakes, and can lead to collision.

Before each tow:

- **Check that the electric brakes work by operating the brake controller inside the tow vehicle.**
- **Check that all lights and turn signals work.**

4.3.5 Attach Breakaway Brake Lanyard

If the coupler or hitch fails, a properly connected and working breakaway brake system will apply the trailer brakes. The safety chains will keep the tow vehicle attached and as the trailer brakes are applied, the trailer/tow vehicle combination will come to a controlled stop.

Connect the lanyard to the tow vehicle so that the

hydraulic actuator will engage or the electric brake pullpin will be pulled out before all of the slack in the safety chains is taken up. Do not connect the lanyard to a safety chain, hitch ball or hitch ball assembly. This would keep the breakaway brake system from operating when it is needed.

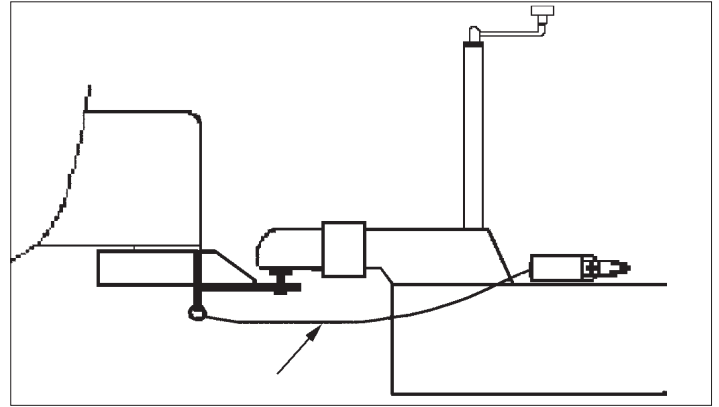

4.3.5.1 Test Electric Brakes

If your trailer has electric brakes, your tow vehicle will have an electric brake controller that sends power to the trailer brakes. Before towing the trailer on the road, you must operate the brake controller while trying to pull the trailer in order to confirm that the electric brakes operate.

While towing the trailer at less than 5 mph, manually operate the electric brake controller in the tow vehicle. You should feel the operation of the trailer brakes. If the trailer brakes are not functioning, the brake system **MUST** be evaluated to determine the cause of the problem and corrective action **MUST** be taken before the trailer is used. Take the unit to your dealer or a qualified brake specialist.

Use this procedure each time you tow the trailer to check brake system operation.

4.3.5.2 Test Electric Breakaway Brakes

The breakaway brake system includes a battery, a switch with a pullpin and lanyard, and a breakaway brake controller. Read and follow the instructions here as well as the instructions that have been prepared by the breakaway brake manufacturer. If you do not have these instructions, contact your dealer for assistance.

Hydraulic tilt trailers may use the hoist battery to provide power to the breakaway brakes. If your trailer is not setup this way, there will be a small breakaway battery mounted near the breakaway switch.

Most trailers are setup to charge the battery from

Coupling To Tow Vehicle

the tow vehicle. If the electrical system on your tow vehicle does not provide power to the battery, you must periodically charge the battery with a commercial battery charger to keep the battery charged.

CAUTION

Extreme cold weather can degrade battery performance and cause brakes to not operate properly.

Check battery charge level before towing.

Do not tow trailer if the battery requires recharging. A discharged brake battery will not activate the brakes if the trailer uncouples from the tow vehicle. The battery must be fully charged before towing trailer.

To test the breakaway brake battery, remove the pullpin from the switch and attempt to pull the trailer forward. You should feel the trailer resisting being towed, but the wheels will not necessarily be locked. If the brakes do not function, do not tow the trailer until brakes, or battery, are repaired.

Immediately replace the pullpin. The breakaway brake battery discharges rapidly when the pullpin is removed.

WARNING

An ineffective breakaway brake system can result in a runaway trailer, leading to death or serious injury if the coupler fails.

Test the function of the breakaway brake system before towing trailer. Do not tow trailer if breakaway brake system is not working; have it serviced or repaired.

Connect breakaway lanyard to the tow vehicle, NOT to the safety chain, ball, pintle, hitch, or support.

Do not tow the trailer with the breakaway brake system ON because the brakes will overheat which can result in permanent brake failure.

WARNING

Failure to replace the pullpin can result in ineffective brakes, leading to loss of control, serious injury or death.

If you do not use your trailer for three or more months, or during winter months:

- Store the battery indoors; and
- Charge the battery every three months.

Replace the breakaway brake battery according to the intervals specified by battery manufacturer.

4.3.5.3 Test Surge Brakes (If Equipped)

Hydraulic surge actuator systems provide automatic and smooth trailer braking without special application by the tow vehicle driver. While this is extremely convenient it can sometimes be difficult to determine if the surge setup is functioning properly. The following steps provide a quick field-test to confirm that the trailer brake system is operational.

WARNING

The field-test procedure indicates only if the trailer brake system is functional, but DOES NOT provide information on how efficiently it will operate.

Regular inspection, maintenance, and adjustment of all brake system components (including the surge actuator, tubing, hoses, brake clusters, drums, and associated hardware/support structure) are still required to ensure maximum brake performance and smooth, even brake operation.

Move the trailer to flat, level ground, pulling FORWARD several feet before parking. This forward motion will ensure trailers equipped with free-backing brakes are in their normal operating mode. Disconnect the trailer from the tow vehicle and jack up the trailer's tongue until it is horizontal. Hook the trailer's safety chains (NOT the actuator's breakaway cable) together to form a loop, which is centered below the actuator's coupler. Place wheel chock blocks two feet behind the trailer to prevent a runaway trailer.

Place a sturdy board, such as a 2 inch by 4 inch piece of lumber, into the chain loop below the coupler.

Coupling To Tow Vehicle

The board should be 4 feet or longer so it will extend several feet above the actuator. Keep the end of the board a few inches off the ground, and position it to press against the front end of the actuator's coupler. Press the board towards the rear of the trailer.

Keep pressing the top of the board to stroke the actuator and its internal master cylinder. If the trailer brake system is operational, the brakes will apply and keep the trailer from rolling away from you. Properly adjusted uni-servo or duo-servo type brakes will prevent you from moving the trailer back more than a few inches. Free-backing type brakes will initially provide rolling resistance, but continued force on the board will switch them into free-backing mode, and you'll be able to move the trailer backwards.

If you have uni-servo or duo-servo brakes, and stroking the actuator (as described above) causes the trailer to roll away from you freely or with only minimal resistance, the brakes are NOT applying properly. If you have free-backing brakes and stroking the actuator (as described above) causes the trailer to roll away without initial resistance, then the brakes are NOT applying properly. The brake system MUST be evaluated to determine the cause of the problem and corrective action MUST be taken before the trailer is used. Use this procedure each time you tow your trailer to check your surge brake system operation.

4.3.5.4 Test Surge Breakaway System

Before towing, check that the breakaway lever and lanyard are properly positioned. If the breakaway lever and lanyard are not located correctly due to either the lanyard being pulled during use or by accident, it MUST be reset prior to the trailer being moved.

See the Surge Brake Actuator manual for the correct resetting and testing procedure.



WARNING

The breakaway system is designed to operate if the trailer separates from the tow vehicle.

DO NOT use the breakaway system as a parking brake.

4.4 Uncouple Trailer

Follow these steps to uncouple trailer from the tow vehicle:

1. Park the trailer on a firm level surface and block trailer tires.
2. Disconnect electrical connector.
3. Disconnect breakaway brake switch lanyard.
4. Disconnect safety chains from tow vehicle.
5. Unlock the coupler and open it.
6. Before extending jack, make certain the ground surface below the jack pad will support the tongue load.
7. Rotate jack handle to extend the jack and transfer the weight of the trailer tongue to the jack.
8. Raise the trailer coupler above the tow vehicle hitch.
9. Drive tow vehicle forward.

4.5 Tongue Weight

It is critical to have a portion of the trailer load carried by the tow vehicle. That is, the trailer tongue must exert a downward force on the hitch. This is necessary for two reasons. First, the proper amount of tongue weight is necessary for the tow vehicle to be able to maintain control of the tow vehicle/trailer system. If, for example, the tongue exerts an upward pull on the hitch, instead of pushing down on it (because the trailer is overloaded behind its axle(s)), the rear wheel of the tow vehicle can lose traction or grip and cause loss of control. Also, even if there is some weight on the tongue, but not enough weight on the tongue, the trailer can become unstable at high speeds. Remember, the faster you go the more likely the trailer is to sway.

If there is too much tongue weight, the tow vehicle is prone to jack-knife. The front wheels of the tow vehicle can be too lightly loaded and cause loss of steering control and traction, if the front wheels are driving.

In addition to tow vehicle control, tongue weight is necessary to insure that the trailer axle(s) do not exceed their Gross Axle Weight Rating (GAWR).

In the following table, the second column shows the rule of thumb percentage of total weight of the trailer plus its cargo (Gross Trailer Weight, or "GTW") that should appear on the tongue of the trailer. For example, a large trailer with a loaded weight of 6,000 pounds, should have 10-15% of 6,000 pounds (600-900 lbs.) on the hitch.

Coupling To Tow Vehicle

Tongue Weight as a Percentage of Loaded Trailer Weight	
Type of Hitch	Percentage
Ball Hitch or Ring & Pintle	10-15% for large trailers 6-10% for small trailers

The numbers quoted are for example purposes only and should be tailored to the specific trailer.

For questions regarding the actual percent of tongue weight for the trailer, check with the manufacturer for specifics.



WARNING

Improper tongue weight (load distribution) can result in loss of control of the trailer, leading to death or serious injury.

Make certain that tongue weight is within the allowable range.

Be sure to:

- **Distribute the load evenly, right and left.**
- **Keep the center of gravity low.**
- **Distribute the load front-to-rear to provide proper tongue weight (see chart).**

4.5.1 Checking Tongue Weight

To check the tongue weight, the tow vehicle and trailer must be on level ground, as they will be when the trailer is being towed.

Take the trailer to a truck stop or grain elevator where there is a “certified” scale. Place the tow vehicle only onto the scale and get the weight. This weight must be less than your tow vehicle’s GVWR.

Pull the trailer onto the scale and uncouple it from the tow vehicle, leaving just the trailer on the scale. Get a ticket which lists the total trailer weight. Re-connect the trailer to your tow vehicle and the drive the tow vehicle wheels off the scale, just leaving the trailer axles on the scale. Get a “ticket”, which lists the trailer’s axle weight. Simply subtract the axle weight from the total weight to determine the hitch weight.

While you are at the scale, you should weigh the entire combination vehicle. This result should be less than the Gross Combined Weight Rating (GCWR) for your towing vehicle. Some scales allow you to get individual axle weights also. If this is possible, get the tow vehicles front and rear axle weights to make sure they are in the

same proportion as the tow vehicle alone, and that the rear axle is not overloaded.

4.6 Adjust Hitch Height (If Equipped)

The height of the hitch on the trailer must be adjusted so that the trailer, when loaded to rated capacity, is level while connected to the tow vehicle. A level trailer allows equal weight distribution on the axles.

Your dealer or a trailer service center can perform this adjustment or you can use the following steps to adjust the hitch height yourself.

If the trailer is not equipped with an adjustable hitch, an offset ball mount may be available from your hitch manufacturer.



WARNING

Improper hitch height adjustment can result in overloaded tires, blowout and loss of control, leading to death or serious injury.

Adjust the hitch height so that the loaded trailer is level.

1. Connect trailer to tow vehicle and load the trailer to rated capacity. See Loading And Unloading.
2. Park the tow vehicle and trailer on a firm level surface.
3. Stand away from the trailer and visually verify if the trailer is level front-to-rear. If the front of the trailer is higher than the rear, the hitch must be raised. If the front of the trailer is lower than the rear, the hitch must be lowered.
4. Uncouple trailer from tow vehicle. See Coupling And Uncoupling.
5. Remove the lock nuts and bolts (1) on hitch. Discard lock nuts. Inspect bolts for damage and replace if necessary. Contact your dealer for the correct size and grade of bolts.



WARNING

Used lock nuts are prone to loosen, resulting in the hitch separating from the trailer, which can lead to death or serious injury.

NEVER re-use a lock nut.

Use new lock nuts each time the hitch height is adjusted.

Contact your dealer for the proper grade and size of lock nut.

6. Raise or lower the hitch as necessary.
7. Install bolts and new lock nuts.
8. Tighten lock nuts to torque specified by your dealer.
9. Couple the trailer to the tow vehicle and verify that the trailer is level front to rear. Adjust if necessary.
10. Unload trailer. See Loading And Unloading.

5. Loading And Unloading

Improper trailer loading causes many accidents and deaths. To safely load a trailer, you must consider:

- Overall load weight.
- Load weight distribution.
- Proper tongue weight.
- Securing the load properly.

To determine that you have loaded the trailer within its rating, you must consider the distribution of weight, as well as the total weight of the trailer and its contents. The trailer axles carry most of the total weight of the trailer and its contents (Gross Vehicle Weight, or “GVW”). The remainder of the total weight is carried by the tow vehicle hitch.

It is essential for safe towing that the trailer tongue and tow vehicle hitch carry the proper amount of the loaded trailer weight, otherwise the trailer can develop an undesirable sway at towing speeds, or the rear of the towing vehicle can be overloaded. Read the “Tongue Weight” information in Section 4.

The load distribution must be such that no component part of the trailer is loaded beyond its rating. You must consider the rating of the tires, wheels and axles. For tandem and triple axle trailers, you must make sure that the front-to-rear load distribution does not result in overloading any axle.

Towing stability also depends on keeping the center of gravity as low as possible. Load heavy items on the floor and over the axles. When loading additional items, be sure to maintain even side-to-side weight distribution and proper tongue weight. The total weight of the trailer and its contents must never exceed the total weight rating of the trailer (Gross Vehicle Weight Rating, or “GVWR”).

Do not transport people, containers of hazardous substances, or flammable liquids. The exception is fuel in the tank of vehicles or equipment being hauled.



WARNING

Do not transport flammable, explosive, poisonous or other dangerous materials on your trailer.

The exception is fuel in the tank of a vehicle or equipment being hauled.



WARNING

Do not transport people on your trailer. Besides putting their lives at risk, the transport of people on a trailer is illegal.

5.1 Loading Trailer

5.1.1 Preparing Trailer For Loading

1. Inspect the floor of the trailer.
2. Inspect the tie down rings and track system for damage, looseness or signs of bending before loading the trailer.



WARNING

Damaged or loose tie down rings or track can break, allowing cargo to become loose.

Loose cargo can shift the center of gravity, and result in loss of control of the trailer.

Inspect and test tie downs and track before loading cargo.

Do not use a damaged or loose tie downs or track to secure cargo.

3. Park the tow vehicle and trailer on a firm and level surface.
4. Clear the area around the trailer.

5.1.2 Loading A Rigid Deck Trailer

1. Couple the trailer to the tow vehicle.



WARNING

Trailer must be coupled to tow vehicle before loading trailer.

2. Lower rear stabilizers (if equipped) or place blocking under rear of trailer so the weight of the cargo does not raise the front of the trailer during loading.

Loading And Unloading

CAUTION

Use a safe lifting procedure to avoid injury when handling ramps.

3. Remove ramps from storage position and secure to rear of trailer. Adjust ramp position to align with equipment tires or tracks.

WARNING

Load can suddenly move or topple, which can result in death or serious injury.

Do not load or unload trailer unless coupled to tow vehicle and is on a firm and level surface.

NOTICE

Ramps are not rated for load bearing capacity. They will NOT support the load bearing capacity of the trailer.

Do not overload ramps.

4. Load the cargo on trailer with approximately 60% of the cargo in the front half of the trailer.
5. Secure the load to the trailer using appropriate straps, chains and tensioning devices. Refer to www.fmcsa.dot.gov for regulations regarding cargo securement rules.
6. Remove ramps and place in storage position.
7. Secure ramps to trailer.
8. Raise rear stabilizers (if equipped) or remove blocking under rear of trailer.

5.1.3 Loading A Tilt Deck Trailer

A tilt deck trailer may be equipped with a manual or a hydraulic tilt deck.

5.1.3.1 Manual Tilt Trailer

1. Couple the trailer to the tow vehicle.

WARNING

Trailer must be coupled to tow vehicle before loading trailer.

2. Release deck latch pin to pivot trailer deck for loading.

WARNING

Loading a pivoting-deck trailer before retracting the deck catch pin can crack the catch pin, which can cause loss of cargo or loss of control of the trailer. Death or serious injury may result.

Before loading the trailer, retract the deck catch pin.

If the deck catch pin becomes bent, do not straighten it. Replace the deck catch pin before towing the load.

3. Load the cargo on trailer with approximately 60% of the cargo in the front half of the trailer. Deck will pivot down into the driving position as the cargo is moved forward on the deck.
4. Extend the deck catch pin into the deck to lock the deck into the driving position. Verify the catch engages the hole in the pivoting deck.

WARNING

An unlocked pivoting deck can result in loss of cargo or loss of control of the trailer, which can result in death or serious injury.

Before towing the trailer:

- Lock the pivoting deck in the driving position.
- Verify that the catch engages the hole in the pivoting deck.

5. Secure the load to the trailer using appropriate straps, chains and tensioning devices. Refer to www.fmcsa.dot.gov for regulations regarding cargo securement rules.

WARNING

Shifting cargo can result in loss of control of the trailer, and can lead to death or serious injury.

Tie down all loads with proper sized fasteners, chains, straps, etc.

Loading And Unloading

5.1.3.2 Hydraulic Tilt Trailer

1. Couple the trailer to the tow vehicle.

WARNING

Trailer must be coupled to tow vehicle before loading trailer.

2. Read and understand the hoist operating procedure before operating the tilt deck.
3. Locate the tilt deck controller. Position yourself in a safe location clear of the tilt deck.
4. Press and hold button to raise the tilt deck. Release the button when the rear of the tilt deck touches the ground.
5. Load the cargo on trailer with approximately 60% of the cargo in the front half of the trailer.
6. Secure cargo to prevent movement.
7. Press and hold button to lower the tilt deck. Release the button when the tilt deck is in the driving position.
8. Secure the load to the trailer using appropriate straps, chains and tensioning devices. Refer to www.fmcsa.dot.gov for regulations regarding cargo securement rules.
9. Stow controller.

WARNING

Shifting cargo can result in loss of control of the trailer, and can lead to death or serious injury.

Tie down all loads with proper sized fasteners, chains, straps, etc.

5.2 Unload Trailer

5.2.1 Unload Manual Tilt Trailer

1. Couple the trailer to the tow vehicle.

WARNING

Trailer must be coupled to tow vehicle before unloading trailer.

2. Park the tow vehicle and trailer on a firm and level surface.
3. Clear the area around the trailer.
4. Remove chains, straps and tensioning devices.

5. Release deck latch pin to pivot trailer deck for unloading.

WARNING

Unloading a pivoting-deck trailer before retracting the deck catch pin can crack the catch pin, which can cause loss of cargo or loss of control of the trailer. Death or serious injury may result.

Before unloading the trailer, retract the deck catch pin.

If the deck catch pin becomes bent, do not straighten it. Replace the deck catch pin before towing the load.

6. Carefully move cargo toward rear of trailer. Deck will pivot down into the unload position as the cargo is moved rearward on the deck.
7. Pivot deck back to the driving position and extend the deck catch pin to lock the deck. Verify the catch engages the hole in the pivoting deck.

WARNING

An unlocked pivoting deck can result in loss of cargo or loss of control of the trailer, which can result in death or serious injury.

Before towing the trailer:

- Lock the pivoting deck in the driving position.
- Verify that the catch engages the hole in the pivoting deck.

5.2.2 Unload Hydraulic Tilt Trailer

1. Couple the trailer to the tow vehicle.

WARNING

Trailer must be coupled to tow vehicle before unloading trailer.

2. Park the tow vehicle and trailer on a firm and level surface.
3. Clear the area around the trailer.
4. Remove chains, straps and tensioning devices.
5. Read and understand the hoist operating procedure

- before operating the tilt deck.
6. Locate the tilt deck controller. Position yourself in a safe location clear of the tilt deck.
 7. Press and hold button to raise the tilt deck. Release the button when the rear of the tilt deck touches the ground.
 8. Unload the cargo from trailer.
 9. Press and hold button to lower the tilt deck. Release the button when the tilt deck is in the driving position.
 10. Stow controller.

5.3 Hydraulic Components

Do not alter or substitute and hydraulic components on the trailer. The hydraulic system is designed with each component being compatible with the safe and reliable operation of the hydraulic system. **Under no circumstances should you alter the hydraulic pressure or flow rate in the hydraulic system.**

DANGER

Crushing hazard.

An altered or component substituted hydraulic system may malfunction, resulting in the tilt deck falling without warning.

NEVER alter or substitute any hydraulic system component.

Always have the hydraulic system repaired or maintained by a qualified technician.

5.4 Securing Cargo

WARNING

Shifting cargo can result loss of control of the trailer, and can lead to death or serious injury.

Tie down all loads with proper sized fasteners, chains, straps, etc.

Refer to www.fmcsa.dot.gov for regulations regarding cargo securement rules.

6. Pre-Tow Checklist

6.1 Pre-Tow Checklist

Before towing, double-check all of these items:

- Tires, wheels and lug nuts. See “Breaking In A New Trailer” section of this manual.
- Tire Pressure. Inflate tires on trailer and tow vehicle to the pressure stated on the Certification / VIN label.
- Coupler secured and locked. See “Coupling To Tow Vehicle” section of this manual.
- Safety chains properly rigged to tow vehicle, not to hitch or ball. See “Coupling To Tow Vehicle” section of this manual.
- Test Tail, Stop, and Turn Lights.
- Test trailer brakes.
- Safety breakaway lanyard fastened to tow vehicle, not to safety chains. See “Coupling To Tow Vehicle” section of this manual.
- Cargo properly loaded, balanced and tied down. See the appropriate “Loading And Unloading” section of this manual.
- Tongue weight and weight distribution set-up.
- Ramps secured for travel.
- Fire extinguisher.
- Flares and reflectors.

6.2 Make Regular Stops

After each 50 miles, or one hour of towing, stop and check the following items:

- Coupler secured.
- Safety chains are fastened and not dragging.
- Cargo secured.

7. Breaking In A New Trailer

7.1 Retighten Lugs At First 10, 25 & 50 Miles

Wheel lugs can shift and settle quickly after being first assembled, and must be checked after the first 10, 25 and 50 miles of driving. Failure to perform this check may result in a wheel coming loose from the trailer, causing a crash leading to death or serious injury. Improper tightening of the lug nuts or bolts voids the axle warranty.

Refer to the Inspection, Service and Maintenance section of this manual.

WARNING

Lug nuts or bolts are prone to loosen after being first assembled. Death or serious injury can result.

Check lug nuts or bolts for tightness on a new trailer, and after re-mounting a wheel at 10, 25 and 50 miles.

7.2 Adjust Brake At First 200 Miles

Brake shoes and drums experience a rapid initial wear. The brakes must be adjusted after the first 200 miles of use, and each 3,000 miles thereafter. Some axles are fitted with a mechanism that will automatically adjust the brake shoes.

Read your axle and brake manual to see if your brakes adjust automatically. If you do not have the axle and brake manual, contact your dealer for assistance.

If your trailer is not fitted with automatically adjusting brakes, the brakes will need to be manually adjusted. See section 9 for instructions.

7.3 Synchronizing Brake Systems

Trailer brakes are designed to work in synchronization with the brakes on the tow vehicle. When the tow vehicle and trailer braking systems are synchronized, both braking systems contribute to slowing, and the tongue of the trailer will neither dive nor rise sharply.

WARNING

If trailer and tow vehicle brakes do not work properly together, death or serious injury can occur.

Road test the brakes in a safe area at no more than 30 m.p.h. before each tow.

To insure safe brake performance and synchronization, read and follow the axle/brake and the brake controller manufacturers' instructions. If you do not have these instructions, contact your dealer for assistance.

8. Accessories

This section provides some basic information for the safe operation of accessories.

You must read and follow these instructions before using the accessory. If you are uncertain whether you have all of the instructions, contact your dealer before operating the accessory.

8.1 Accessory Battery

Your trailer may be equipped with an accessory battery that operates the tilt deck.

The battery may be kept charged either by the tow vehicle, by an auxiliary charger or by using an on-board battery maintainer/charger (if equipped). If the trailer is used daily, it is recommended that the battery charger be plugged in after each days use. The battery may be located in a tongue mounted battery box or a side mounted box.

The accessory battery must be kept in a charged condition during storage. The battery could freeze and break if it becomes discharged.

If the battery is not fully charged, the hydraulic pump will lose pressure which may cause hydraulic fluid to flow back into the hydraulic reservoir, overfilling the reservoir and ejecting fluid into the battery box.



WARNING

Risk of battery exploding.

Battery box prop rod may contact battery terminals, which may result in the battery exploding.

Place battery box lid prop rod in retaining clip.

9. Inspection, Service And Maintenance

9.1 Inspection, Service & Maintenance Summary Charts

You must inspect, maintain and service your trailer regularly to insure safe and reliable operation. If you cannot or are unsure how to perform the items listed here, have your dealer do them. Note: In addition to this manual, also check the relevant component manufacturer's manual.

Inspection And Service Before Each Tow		
Item	Inspection/Service	Manual Section Reference
Breakaway Brakes • Electric • Hydraulic	Check operation. Check operation.	Section 4. Section 4.
Breakaway Battery	Fully charged, connections clean.	Section 4 and 9.
Brakes • Electric • Surge	Check operation. Check operation. Check master cylinder level.	Section 4 and 9.
Shoes And Drums	Adjust	Section 9.
Safety Chains And Hooks	Check for wear, damage.	Section 4.
Coupler And Hitch Ball	Check for cracks, pits, and flats. Replace w/ ball and coupler having trailer GVW Rating. Grease. Check locking device & replace when worn.	Section 4 and 9. Section 4 and 9. Section 4 and 9.
Ring And Pintle	Check for cracks, pits, and flats. Replace w/ ring and pintle having trailer GVW Rating. Grease. Check locking device & replace when worn.	Section 4 and 9. Section 4 and 9. Section 4 and 9.
Tires	Check tire pressure when cold. Inflate as needed. Check for damage.	Section 6 and 9 Section 6 and 9
Wheels - Lug Nuts Or Bolts & Hub	Check for tightness. Tighten. For new and remounted wheels, check torque after first 10, 25 & 50 miles of driving and after any impact.	Section 6. Section 7 and 9.

Inspection, Service And Maintenance

Inspection And Service Every Month		
Item	Inspection / Service	Manual Section Reference
Lubrication	Lubricate tilt deck pivot points (if equipped).	Section 9.
	Lubricate hydraulic cylinder ends (if equipped).	Section 9.

Inspection and Service Every 6 Months or 6,000 Miles		
Item	Inspection/Service	Manual Section Reference
Brakes, electric • Magnet • Controller (in tow vehicle)	Check wear and current draw.	Section 9.
	Check power output (amperage) and modulation.	Section 9. See Controller Mfr's Manual
Tires	Inspect tread and sidewalls thoroughly.	Section 9.
	Replace tire when treads are worn, when sidewall has a bulge, or sidewall is worn.	Section 9.
	Rotate every 5,000 Miles.	Section 9.
Brakes • Electric • Surge	Check Operation. Check Operation. Check Master Cylinder Level.	Section 4.
Brake Shoes And Drums	Adjust	Section 7 and 9.
Safety Chains & Hooks	Check for wear, damage.	Section 4.
Coupler And Hitch Ball	Check for cracks, pits, and flats. Replace w/ ball and coupler having trailer GVW Rating.	Section 4.
	Grease.	Section 4 and 9.
	Check locking device and replace when worn.	Section 4 and 9.
Ring And Pintle	Check for cracks, pits, and flats. Replace w/ ring and pintle having trailer GVW Rating.	Section 4.
	Grease.	Section 4 and 9.
	Check locking device & replace when worn.	Section 4 and 9.

Inspection, Service And Maintenance

Inspection And Service Every Year or 12,000 Miles		
Item	Inspection/Service	Manual Section Reference
Brakes, all types <ul style="list-style-type: none"> • Shoes and Drums 	Check for scoring and wear. Replace per manufacturer's specifications.	Section 9. See Brake Mfr's Manual
Jack, Drop-leg (if equipped)	Grease gears at top.	See Jack Mfr's Manual
Structure <ul style="list-style-type: none"> • Frame Members 	Inspect all frame members, bolts & rivets. Repair or replace damaged, worn or broken parts.	Section 9.
<ul style="list-style-type: none"> • Welds 	Inspect all welds. Repair as needed.	Section 9.
Wheels <ul style="list-style-type: none"> • Wheel Bearings 	Disassemble / inspect / assemble and repack. Replace promptly if immersed in water.	Section 9 & See Axle Mfr's Manual
<ul style="list-style-type: none"> • Rims 	Inspect for cracks & dents. Replace as needed.	
Structure <ul style="list-style-type: none"> • Axle Attachment Bolts 	Check BY DEALER	Section 9.

9.2 Inspection And Service Instructions

WARNING

Worn or broken suspension parts can cause loss of control and injury may result.

Have trailer professionally inspected annually and after any impact.

To perform many of the inspection and maintenance activities, you must jack up the trailer.

When jacking and using jack stands, place them so as to clear wiring, brake lines, and suspension parts (springs, torsion bars, etc.). Place jacks and jack stands under the outer frame rail to which the axles are attached.

WARNING

Never go under trailer unless it is on firm and level ground and resting on properly placed and secured jack stands.

WARNING

Crushing hazard.

The tow vehicle and trailer could be inadvertently moved while a person is under the trailer.

The tow vehicle engine must be off, ignition key removed and parking brakes set before entering the area under the trailer.

9.2.1 Trailer Structure

Wash the trailer as needed with a power washer and a detergent solution.

9.2.1.1 Fasteners And Frame Members

Inspect all fasteners and structural frame members for bending and other damage, cracks, or failure. Repair or replace any damaged fastener and repair the frame member. If you have any questions about the condition or method of repair of fasteners or frame members, get the recommendation of, or have the repair done by your dealer.

WARNING

Broken or damaged fasteners can cause injury or damage to trailer and contents.

Inspect for, and repair all damaged parts at least once a year.

9.2.1.2 Welds

All welds can crack or fail when subjected to heavy loads or movement of cargo that was not properly secured. Any time that you know or suspect that the trailer has been subjected to heavy loads or movement of cargo, immediately inspect the welds and fasteners for damage. To prevent severe damage to your trailer, inspect all of the welds for cracks or failure at least once a year. If a weld failure is detected, contact your dealer.

WARNING

Do not attempt to repair a cracked or broken weld unless you have the skills and equipment to make the repair.

Improper weld repair will lead to early failure of the trailer structure and serious injury or death.

See your dealer for weld repairs.

WARNING

Broken or damaged welds can cause injury or damage to trailer and contents.

Inspect for, and repair all damaged parts at least once a year.

9.2.2 Trailer Brakes - Electric

9.2.2.1 Brake Discs, Shoes And Drums

Properly functioning brake shoes and drums are essential to ensure safety. You must have your dealer inspect these components at least once per year, or each 12,000 miles. Brake adjustment is not covered under the axle warranty.

The brake shoes must be adjusted after the first 200 miles of use, and each 3,000 miles thereafter. Most axles are fitted with a brake mechanism that will

automatically adjust the brake shoes when the trailer is “hard braked” from a rearward direction. Trailer disc brakes are self-adjusting and do not need to be periodically adjusted. Using pads or shoes without enough brake lining material can result in brake damage, create excessive heat and potentially cause the loss of braking capacity. Read your axle and brake manual to see how to adjust your brakes. If you do not have this manual, contact your dealer for assistance.

9.2.2.2 Manually Adjusting Brake Shoes

Some braking systems are not automatically adjusted. These brakes require manual adjustment. The following steps apply to adjust most manually adjustable brakes.

Read your axle and brake manual to see how to adjust your brakes. If you do not have this manual, contact your dealer for assistance.

1. Jack up the trailer and secure it on adequate capacity jack stands.
2. Be sure the wheel and brake drum rotate freely.
3. Remove the adjusting-hole cover from the adjusting slot on the bottom of the brake backing plate.
4. With a screwdriver or standard adjusting tool, rotate the starwheel of the adjuster assembly to expand the brake shoes. Adjust the brake shoes out until the pressure of the linings against the drum makes the wheel very difficult to turn. Note: Your trailer maybe equipped with drop spindle axles. See axle manual for your axle type. You will need a modified adjusting tool for adjusting the brakes in these axles.
5. Rotate the starwheel in the opposite direction until the wheel turns freely with a slight drag.
6. Replace the adjusting-hole cover.
7. Repeat the above procedure on all brakes.
8. Lower the trailer to the ground.

9.2.2.3 Electric Brakes

Two different types of electric brakes may be present on the trailer: an emergency electric breakaway system, which acts only if the trailer comes loose from the hitch and the breakaway pin is pulled. The other brake is an electric braking system that acts whenever the brakes of the tow vehicle are applied.

Breakaway Battery - This battery supplies the power to operate the trailer brakes if the trailer uncouples from the tow vehicle. Be sure to check, maintain and replace the battery according to the battery manufacturer’s instructions. Your trailer may use the hydraulic system battery to operate the breakaway brakes.

CAUTION

Extreme cold weather can degrade battery performance and cause brakes to not operate properly.

Check battery charge level before towing.

Breakaway Switch - This switch engages the electric brakes if the trailer uncouples from the tow vehicle.

To check for proper functioning of the switch, battery and brakes, you must pull the pin from the switch and confirm that the brakes apply to each wheel. You can do this by trying to pull the trailer with the tow vehicle, after pulling the pin. The trailer brakes may not lock, but you will notice that a greater force is needed to pull the trailer.

WARNING

If electric breakaway brakes do not operate when trailer is uncoupled from the tow vehicle, death or serious injury can occur.

Check emergency breakaway brake system before each tow.

9.2.2.4 Tow Vehicle Operated Electric Brakes

The electric brakes that operate in conjunction with the tow vehicle brakes must be “synchronized” so that braking is properly distributed to the tow vehicle brakes and the trailer brakes. For proper operation and synchronization, read and follow the axle/brake and the brake controller manufacturers’ instructions. If you do not have these instructions, contact your dealer for assistance.

9.2.2.5 Electric Brake Magnets

To make certain an electrically-operated braking system will function properly, you must have your dealer inspect the magnets at least once a year, or each 12,000 miles. See the brake manual for wear and current inspection instructions.

9.2.3 Trailer Brakes - Surge (If Equipped)

9.2.3.1 Surge Brake Master Cylinder

Check fluid level prior to using the trailer. The master cylinder is normally located on the tongue of the trailer.

The fluid level must be maintained at full mark on reservoir. Check with your dealer for the type of brake fluid used in the brake system.

9.2.3.2 Hydraulic Surge Brake

Before each tow, perform the following steps:

1. Check that the brake master cylinder level as instructed above. Check for leaks and repair as required.
2. Examine the actuator for wear, bent parts, corroded/seized parts, or other damage. Have the affected components replaced with genuine service parts.
3. Check to determine that the actuator mounting bolts are tightened to the manufacturer's specification.
4. Test the actuator and brake function as described in the Coupling To Tow Vehicle section of this manual. Actuator travel over one inch indicates that the brakes need adjustment (or that the actuator has been structurally damaged). Actuator travel is the distance the coupler case assembly moves to the outer case during braking. Adjust the brakes following the instructions given in the brake installation manual. Failure to adjust brakes will result in loss of braking.
5. Before storage or after extended use, apply motor oil to the coupler components and the internal rollers to keep them moving freely and to prevent corrosion.
6. See the surge brake manufacturer's manual for other inspection and maintenance activities. If you do not have this manual, contact your dealer for assistance.

9.2.3.3 Master Cylinder Bleeding

Remove the master cylinder's cap and fill the reservoir to three quarters full with DOT-3 or DOT 4 brake fluid. DO NOT allow brake fluid to contact painted surfaces since it will damage the finish. Wipe up any spills immediately and wash the area with water.

Bleed the brake system manually or with a pressure bleeder. Pressure bleeding equipment simplifies the process, and is available at most automotive supply stores. Use the instructions provided with the pressure bleeder. If you chose to manually bleed the system, an assistant is required. Use the following steps to manually bleed the brake system:

1. Disconnect the trailer from the tow vehicle and jack the trailer's tongue until it is horizontal. Make sure that the wheels are blocked so that the trailer will not roll away.
2. Fill the master cylinder with correct fluid.
3. Install a bleeder hose on the bleeder screw of the

farthest wheel cylinder from the actuator. If the trailer has multiple axles, bleed the rear axle first. Submerge the other end of the hose in a glass container of brake fluid, so that air bubbles can be observed.

4. Open the bleeder screw and have an assistant stroke (but not release) the actuator. Brake fluid and/or air bubbles will flow into the jar. Close the bleeder screw. The helper can then allow the actuator to return to its rest position.
5. Repeat the process until no more bubbles are released with the stroke. Air trapped in the brake lines will greatly reduce your braking efficiency. Be sure to close the bleeder screw securely when the cylinder is fully bled. Repeat the bleeding operation at each wheel cylinder. During the bleeding process, replenish the master cylinder reservoir with fresh brake fluid so that the level does not fall below half full. This will ensure that no air is drawn into the system.
6. After all brakes have been bled, refill the master cylinder before operating. Be sure to install the master cylinder filler cap.



WARNING

Use only fresh brake fluid from a sealed container. DO NOT reuse fluid. After filling and bleeding, refill the actuator.

Failure to maintain an adequate fluid level may cause brake failure.

9.2.4 Trailer Connection To Tow Vehicle

9.2.4.1 Coupler And Ball

Before each tow, coat the ball with a thin layer of automotive bearing grease to reduce wear and ensure proper operation; and check the locking device that secures the coupler to the ball for proper operation.

See the coupler manufacturer's manual for other inspection and maintenance procedures. If you do not have this manual, contact your dealer for assistance.

If you see or feel evidence of wear, such as flat spots, deformations, pitting or corrosion, on the ball or coupler, immediately have your dealer inspect them to determine the proper action to prevent possible failure of the ball and coupler system. All bent or broken coupler parts must be replaced before towing the trailer.

The coupler latch lever must be able to rotate freely and automatically snap into the latched position. Oil the pivot points, sliding surfaces, and spring ends with SAE 30W motor oil. Keep the ball pocket and latch mechanism clean. Dirt or contamination can prevent proper operation of the latching mechanism.

When replacing a ball, the load rating must match or exceed the GVWR of the trailer.

9.2.4.2 Ring And Pintle

Before each tow, coat the ring with a thin layer of automotive bearing grease to reduce wear and ensure proper operation; and check the locking device that secures the pintle to the ring for proper operation.

See the pintle manufacturer's manual for other inspection and maintenance activities. If you do not have this manual, contact your dealer for assistance.

If you see or feel evidence of wear, such as flat spots, deformations, pitting or corrosion, on the ring or pintle, immediately have your dealer inspect them to determine the proper action to prevent possible failure of the ring and pintle system. All bent or broken coupler parts must be replaced before towing the trailer.

The pintle handle lever must be able to rotate freely and automatically snap into the latched position. Oil the pivot points, sliding surfaces, and spring ends with SAE 30W motor oil. Keep the ring pocket and latch mechanism clean. Dirt or contamination can prevent proper operation of the latching mechanism.

When replacing a ring, the load rating must match or exceed the GVWR of the trailer.

9.2.5 Landing Leg Or Jack

If a grease fitting is present, use a grease gun to lubricate the jack mechanism. Grease the gears in the top of hand-cranked jacks once a year, by removing the top of the jack and pumping or hand packing grease into the gears.

9.2.6 Lights And Signals

Before each tow, check all trailer lights for proper operation.



To avoid risk of collisions, all lights must work.

9.2.7 Wheel Rims

If the trailer has been struck, or impacted, on or near the wheels, or if the trailer has struck a curb, inspect the rims for damage. Replace any damaged wheel. Inspect the wheels for damage every year, even if no obvious impact has occurred.

9.2.8 Tires

Before each tow, check the tire pressure to make sure it is at the level indicated on the tire sidewall or VIN label. Tire pressure must be checked while the tire is cold. Do not check tire pressure immediately after towing the trailer. Allow at least three hours for the tires to cool, if the trailer has been towed for as much as one mile. Tires can lose air over a period of time.

Replace the tire before towing the trailer if the tire treads have less than 2/32 inch depth or the telltale bands are visible.

A bubble, cut or bulge in a side wall can result in a tire blowout. Inspect both side walls of each tire for any bubble, cut or bulge; and replace a damaged tire before towing the trailer.

If you are storing your trailer for an extended period, make sure the tires are inflated to the maximum rated pressure indicated on the sidewall or VIN label and that you store them in a cool, dry place such as a garage. Use tire covers to protect the tires from the harsh effects of the sun.

Inspection, Service And Maintenance

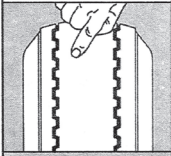
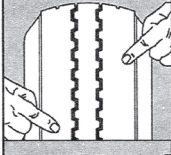
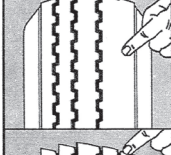
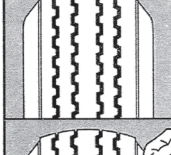
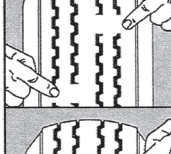
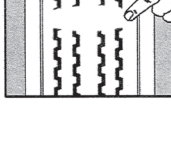
	Condition	Possible Cause	Remedy
	Even Center Wear	Over Inflation	Check & Adjust Pressure When Cold
	Inside & Outside Wear	Under Inflation	Check & Adjust Pressure When Cold
	Smooth, Side Wear - One Side	Loss of Camber or Overloading	Check & Unload As Necessary Have Alignment Checked
	"Feathering" Across The Face	Axle Not Square To Frame or Incorrect Toe In	Square Axles Have Alignment Checked
	Cupping	Loose Bearings or Wheel Balance	Check Bearing Adjustment and Wheel & Tire Balance
	Flat Spots	Wheel Lockup	Adjust Brakes

Tire Inspection Chart



WARNING

Worn, damaged or under-inflated tires can cause loss of control, injury and damage.

Check tires before each tow.

9.2.9 Wheel Bearings

A loose, worn or damaged wheel bearing is the most common cause of brakes that grab.

To check your bearings, jack up the trailer and secure it on adequate capacity jack stands. Check wheels for side-to-side looseness.

If the wheels are loose, or spin with a wobble, the bearings must be serviced or replaced.



WARNING

Never go under trailer unless it is on firm and level ground and resting on properly placed and secured jack stands.

If your axle(s) are equipped with a grease zerk on the ends of the axle(s), the bearings must be greased every 6 months or 6,000 miles to ensure reliable and safe operation of your trailer.

1. Remove the rubber plug from the axle end.
2. Place grease gun on zerk.
3. Pump grease until new grease begins to appear. Use a different color grease each time so you will know when the new grease begins to appear.
4. Install rubber plug and cap. Repeat for remaining wheel bearings.

If your trailer axle(s) are not equipped with grease zerks, refer to the axle manufacturer's manual for service and maintenance information.

9.2.10 Lubrication

Lubricate tilt deck pivots and hydraulic cylinder ends every month (if equipped).

9.2.11 Hydraulic Reservoir

Check fluid level prior to towing the trailer. The reservoir is normally located inside the battery box.

The tilt deck must be fully lowered before checking fluid level. The reservoir should be filled to the full mark on the side of the reservoir.

Use a quality hydraulic fluid with anti-wear properties, rust and oxidation inhibitors. Fluid ejecting from the reservoir could indicate a low battery.

9.2.12 Lug Nuts Or Bolts

Lug nuts or bolts are prone to loosen right after a wheel is mounted to a hub. When driving on a remounted wheel, check to see if the lug nuts or bolts are tight after the first 10, 25 and 50 miles of driving, and before each tow thereafter.



WARNING

Lug nuts or bolts are prone to loosen after being first assembled. Death or serious injury can result.

Check lug nuts or bolts for tightness on a new trailer, and after re-mounting a wheel at 10, 25 and 50 miles.

WARNING

Metal creep between the wheel rim and lug nuts or bolts can cause rim to loosen.

Death or injury can occur if wheel comes off.

Tighten lug nuts or bolts before each tow.

Tighten the lug nuts or bolts in three stages to the final torque for the axle size on your trailer, to prevent wheels from coming loose. Tighten each lug nut or bolt in the order shown in the following figure.

Use a calibrated torque wrench to tighten the fasteners. Verify that wheel studs are free of contaminants such as paint or grease, which may result in inaccurate torque readings. Over-tightening will result in breaking the studs or permanently deforming the mounting stud holes in the wheels, and will void the axle warranty.

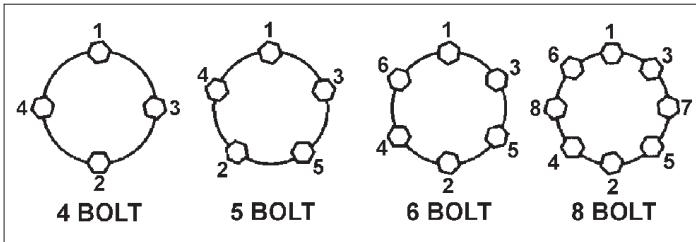

See your axle manufacturers manual or your dealer for wheel nut or bolt torque specifications.

HONDA GX200 OWNER'S MANUAL



INTRODUCTION

Thank you for purchasing a Honda engine. We want to help you to get the best results from your new engine and to operate it safely. This manual contains information on how to do that; please read it carefully before operating the engine. If a problem should arise, or if you have any questions about your engine, consult your servicing dealer.

All information in this publication is based on the latest product information available at the time of printing. Honda Motor Co., Ltd. reserves the right to make changes at any time without notice and without incurring any obligation. No part of this publication may be reproduced without written permission.

This manual should be considered a permanent part of the engine and should remain with the engine if resold.

We suggest you read the warranty policy to fully understand its coverage and your responsibilities of ownership.

Review the instructions provided with the equipment powered by this engine for any additional information regarding engine startup, shutdown, operation, adjustments or any special maintenance instructions.

SAFETY MESSAGES

Your safety and the safety of others are very important. We have provided important safety messages in this manual and on the engine. Please read these messages carefully.

A safety message alerts you to potential hazards that could hurt you or others. Each safety message is preceded by a safety alert symbol  and one of three words, DANGER, WARNING, or CAUTION.

These signal words mean:

 **DANGER**

You **WILL** be **KILLED** or **SERIOUSLY HURT** if you don't follow instructions.

 **WARNING**

You **CAN** be **KILLED** or **SERIOUSLY HURT** if you don't follow instructions.

 **CAUTION**

You **CAN** be **HURT** if you don't follow instructions.

Each message tells you what the hazard is, what can happen, and what you can do to avoid or reduce injury.

DAMAGE PREVENTION MESSAGES

You will also see other important messages that are preceded by the word **NOTICE**.

This word means:

NOTICE

Your engine or other property can be damaged if you don't follow instructions.

The purpose of these messages is to help prevent damage to your engine, other property, or the environment.

©2018 Honda Motor Co., Ltd. –All Rights Reserved

3RZ1C800
00X3R-Z1C-8000

GX200T2 • GX390T2

HONDA

OWNER'S MANUAL MANUEL DE L'UTILISATEUR BEDIENUNGSANLEITUNG MANUAL DEL PROPIETARIO INSTRUKTIEHANDLEIDING MANUALE DELL'UTENTE

GX200 • GX390

LPG-Fueled Engine

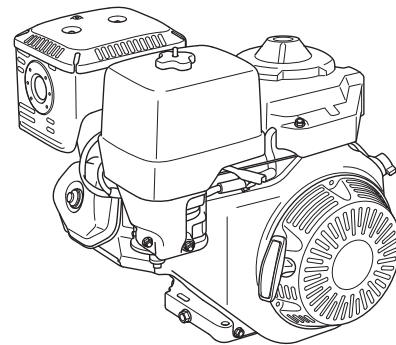

The illustrations herein are mainly based on: PTO shaft type Q.
• The illustration may vary according to the type.

CONTENTS

INTRODUCTION.....	1	AIR CLEANER.....	8
SAFETY MESSAGES.....	1	Inspection.....	8
SAFETY INFORMATION.....	2	Cleaning.....	8
SAFETY LABEL LOCATION... 2		SPARK PLUG.....	9
COMPONENT & CONTROL		IDLE SPEED.....	9
LOCATIONS.....	2	HELPFUL TIPS &	
FEATURES.....	2	SUGGESTIONS.....	10
SETTING.....	3	STORING YOUR ENGINE... 10	
BEFORE OPERATION		TRANSPORTING.....	10
CHECKS.....	3	TAKING CARE OF	
OPERATION.....	4	UNEXPECTED PROBLEMS... 10	
SAFE OPERATING		TECHNICAL INFORMATION... 11	
PRECAUTIONS.....	4	Serial Number Location... 11	
STARTING THE ENGINE... 4		Remote Control Linkage... 11	
STOPPING THE ENGINE... 5		High Altitude Operation... 11	
SETTING ENGINE SPEED... 5		Specifications.....	11
SERVICING YOUR ENGINE... 6		Tuneup Specifications... 11	
THE IMPORTANCE OF		Wiring Diagrams.....	12
MAINTENANCE.....	6	CONSUMER INFORMATION... 12	
MAINTENANCE SAFETY... 6		DISTRIBUTOR/DEALER	
SAFETY PRECAUTIONS... 6		LOCATOR INFORMATION... 12	
MAINTENANCE		CUSTOMER SERVICE	
SCHEDULE.....	6	INFORMATION.....	12
REFUELING.....	6		
ENGINE OIL.....	7		
Recommended Oil.....	7		
Oil Level Check.....	7		
Oil Change.....	7		

ENGLISH

FRANÇAIS

DEUTSCH

ESPAÑOL

NETERLANDS

ITALIANO

SAFETY INFORMATION

- Understand the operation of all controls and learn how to stop the engine quickly in case of emergency. Make sure the operator receives adequate instruction before operating the equipment.
- Do not allow children to operate the engine. Keep children and pets away from the area of operation.
- Your engine's exhaust contains poisonous carbon monoxide. Do not run the engine without adequate ventilation, and never run the engine indoors.
- The engine and exhaust become very hot during operation. Keep the engine at least 1 meter away from buildings and other equipment during operation. Keep flammable materials away, and do not place anything on the engine while it is running.
- LPG is extremely flammable and combustible. Refuel outdoors, in a well-ventilated area, with the engine stopped. Never smoke near LPG and keep other flames and sparks away.

SAFETY LABEL LOCATION

This label warns you of potential hazards that can cause serious injury. Read it carefully.

If the label comes off or becomes hard to read, contact your Honda servicing dealer for replacement.

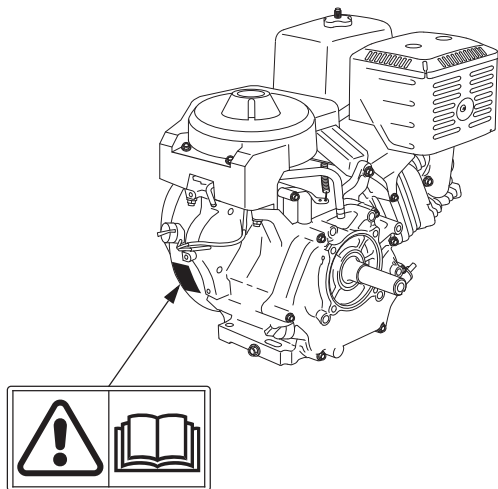

Read Owner's Manual before operation.

COMPONENT & CONTROL LOCATIONS

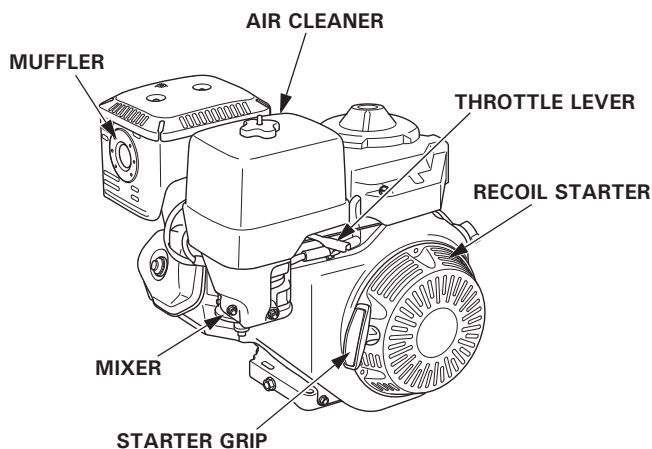
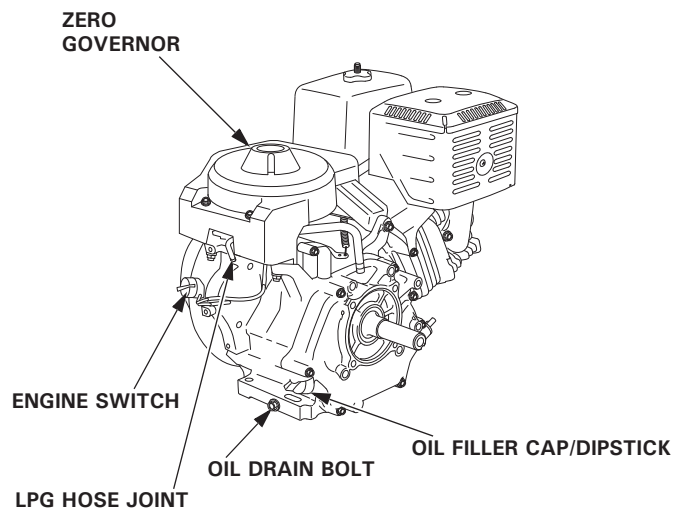

FEATURES

OIL ALERT SYSTEM (applicable types)

The Oil Alert system is designed to prevent engine damage caused by an insufficient amount of oil in the crankcase. Before the oil level in the crankcase can fall below a safe limit, the Oil Alert system will automatically stop the engine (the engine switch will remain in the ON position).

If the engine stops and will not restart, check the engine oil level (see page 7) before troubleshooting in other areas.

SETTING

Fuel System

This engine uses LPG.

You must prepare an LPG cylinder, low pressure regulator, LPG hose, and two hose clamps because these are not included with this engine. Be sure to use parts that are for LPG use.

Also, these are not covered under Honda warranty, so you must perform engine connections and maintenance.

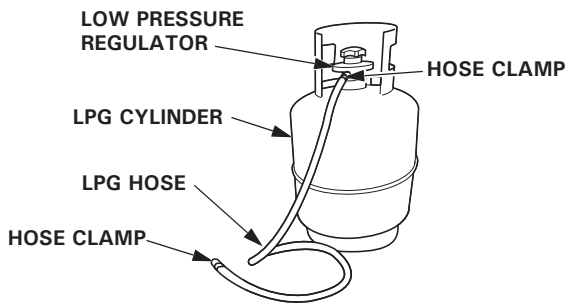

- Use an LPG-compliant LPG hose with an inner diameter of 10 mm.
- Use a LPG hose with a length of 5 m or shorter between the low pressure regulator and engine.
- When handling the LPG hose, keep it away from hot parts and edges.
- Use a low pressure regulator that satisfies the following standard and performance specifications.

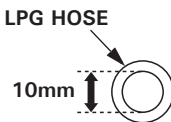

Standard	Based on EN 16129
Gas flow rate	1.2 kg/h or higher (GX200) 3.4 kg/h or higher (GX390)
Excess flow valve*	none

* The excess flow valve may be described as a "safety system" in the Regulator catalog, etc.

- Use an LPG hose and hose clamps that are suited for LPG purposes.
- Attach the LPG hose to the low pressure regulator of the LPG cylinder and the LPG hose joint on the engine.
- When attaching the LPG hose, be sure to use clips to fasten the LPG hose.

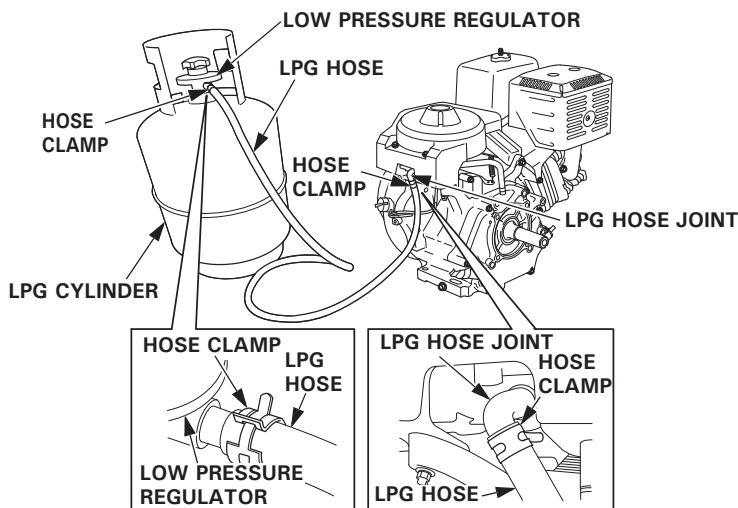

- Keep the engine and LPG cylinder as far apart as possible.
- Use the LPG cylinder while it is standing upright.
- After connecting the engine and LPG cylinder with the LPG hose, apply soapy water and check that there are no gas leaks.

BEFORE OPERATION CHECKS

IS YOUR ENGINE READY TO GO?

For your safety, and to maximize the service life of your equipment, it is very important to take a few moments before you operate the engine to check its condition. Be sure to take care of any problem you find, or have your servicing dealer correct it, before you operate the engine.

⚠ WARNING

Failure to properly maintain this engine, or failing to correct a problem before operation, could result in a significant malfunction.

Some malfunctions can cause serious injuries or death.

Always perform a pre-operation inspection before each operation and correct any problems.

Before beginning your pre-operation checks, be sure the engine is level and the engine switch is in the OFF position.

Always check the following items before you start the engine:

Fuel Gas Connection

You must connect the LPG hose to this engine.

Fuel Gas Leak and LPG Hose Damage Check

Coat the LPG hose joint with soapsuds and check that there is no fuel gas leaks.

Check that the LPG hose is not damaged.

If the LPG hose is damaged or there is a gas leak, discontinue use.

Take measures to fix the connection or replace the parts, and check that there are no gas leaks before starting the engine.

Check the General Condition of the Engine

Before each use, look around and underneath the engine for signs of oil leaks.

1. Remove any excessive dirt or debris, especially around the muffler and recoil starter.
2. Look for signs of damage.
3. Check that all shields and covers are in place, and all nuts, bolts, and screws are tightened.

Check the Engine

Before each use, look around and underneath the engine for signs of oil leaks.

1. Check the engine oil level (see page 7). Running the engine with a low oil level can cause engine damage.

The Oil Alert system (applicable types) will automatically stop the engine before the oil level falls below safe limits. However, to avoid the inconvenience of an unexpected shutdown, always check the engine oil level before startup.

2. Check the air filter element (see page 8). A dirty air filter element will restrict air flow to the mixer, reducing engine performance.
3. Check the equipment powered by this engine.

Review the instructions provided with the equipment powered by this engine for any precautions and procedures that should be followed before engine startup.

OPERATION

SAFE OPERATING PRECAUTIONS

Before operating the engine for the first time, please review the *SAFETY INFORMATION* section on page 2 and the *BEFORE OPERATION CHECKS* on page 3.

For your safety, do not operate the engine in an enclosed area such as a garage. Your engine's exhaust contains poisonous carbon monoxide gas that can collect rapidly in an enclosed area and cause illness or death.

⚠ WARNING

Exhaust contains poisonous carbon monoxide gas that can build up to dangerous levels in closed areas.

Breathing carbon monoxide can cause unconsciousness or death.

Never run the engine in a closed, or even partly closed area.

Review the instructions provided with the equipment powered by this engine for any safety precautions that should be observed with engine startup, shutdown or operation.

STARTING THE ENGINE

1. Start supplying gas.
2. Move the throttle lever away from the MIN. position, about 1/3 of the way toward the MAX. position.

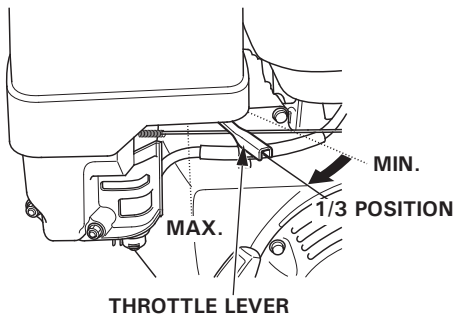

Some engine applications use a remote-mounted throttle control rather than the engine-mounted throttle lever shown here. Refer to the instructions provided by the equipment manufacturer.

3. Turn the engine switch to the ON position.

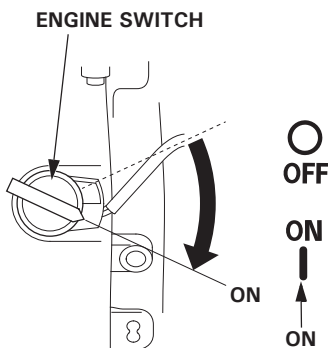

4. If you are starting for the first time after attaching the LPG hose, or if two days or more have passed since you last used the engine, press the priming button once (for about one second).

If you pressed the priming button for too long, you can start by performing the recoil operation several times.

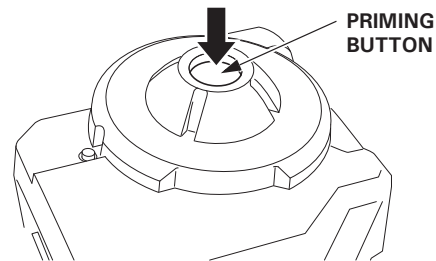

5. Operate the starter.

Pull the starter grip lightly until you feel resistance, then pull briskly in the direction of the arrow as shown below. Return the starter grip gently.

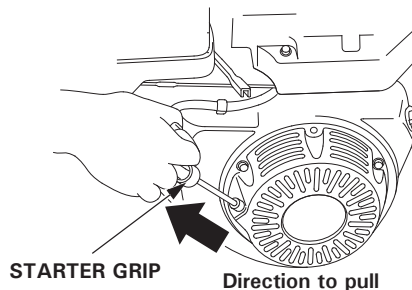

NOTICE

Do not allow the starter grip to snap back against the engine. Return it gently to prevent damage to the starter.

STOPPING THE ENGINE

To stop the engine in an emergency, simply turn the engine switch to the OFF position. Under normal conditions, use the following procedure. Refer to the instructions provided by the equipment manufacturer.

1. Move the throttle lever to the MIN. position.

Some engine applications use a remote-mounted throttle control rather than the engine-mounted throttle lever shown here.

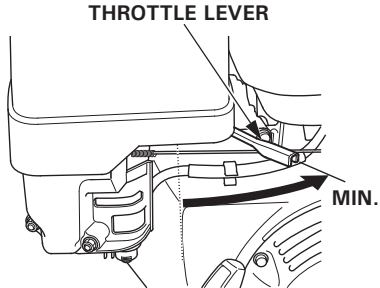

2. Turn the engine switch to the OFF position.

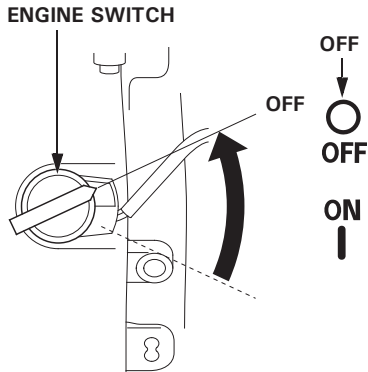

3. Stop supplying gas.

SETTING ENGINE SPEED

Position the throttle lever for the desired engine speed.

Some engine applications use a remote-mounted throttle control rather than the engine-mounted throttle lever shown here. Refer to the instructions provided by the equipment manufacturer.

For engine speed recommendations, refer to the instructions provided with the equipment powered by this engine.

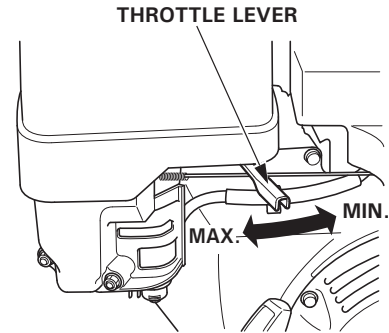

SERVICING YOUR ENGINE

THE IMPORTANCE OF MAINTENANCE

Good maintenance is essential for safe, economical, and trouble-free operation. It will also help reduce pollution.

WARNING

Failure to properly maintain this engine, or failing to correct a problem before operation, could result in a significant malfunction.

Some malfunctions can cause serious injuries or death.

Always follow the inspection and maintenance recommendations and schedules in this owner's manual.

To help you properly care for your engine, the following pages include a maintenance schedule, routine inspection procedures, and simple maintenance procedures using basic hand tools. Other service tasks that are more difficult, or require special tools, are best handled by professionals and are normally performed by a Honda technician or other qualified mechanic.

The maintenance schedule applies to normal operating conditions. If you operate your engine under severe conditions, such as sustained high-load or high-temperature operation, or use in unusually wet or dusty conditions, consult your servicing dealer for recommendations applicable to your individual needs and use.

Use only Honda Genuine parts or their equivalent. The use of replacement parts which are not of equivalent quality may damage the engine.

MAINTENANCE SAFETY

Some of the most important safety precautions follow. However, we cannot warn you of every conceivable hazard that can arise in performing maintenance. Only you can decide whether or not you should perform a given task.

WARNING

Improper maintenance can cause an unsafe condition.

Failure to properly follow maintenance instructions and precautions can cause serious injuries or death.

Always follow the procedures and precautions in this owner's manual.

SAFETY PRECAUTIONS

- Make sure the engine is off before you begin any maintenance or repairs. To prevent unintentional startup, disconnect the spark plug cap. This will eliminate several potential hazards:
 - **Carbon monoxide poisoning from engine exhaust.**
Operate outside away from open windows or doors.
 - **Burns from hot parts.**
Let the engine and exhaust system cool before touching.
 - **Injury from moving parts.**
Do not run the engine unless instructed to do so.
- Read the instructions before you begin, and make sure you have the tools and skills required.
- To reduce the possibility of fire or explosion, be careful when working around LPG. Use only a non-flammable solvent, not gasoline, to clean parts. Keep cigarettes, sparks and flames away from all fuel related parts.

Remember that an authorized Honda servicing dealer knows your engine best and is fully equipped to maintain and repair it. To ensure the best quality and reliability, use only new Honda Genuine parts or their equivalents for repair and replacement.

MAINTENANCE SCHEDULE

REGULAR SERVICE PERIOD (1) Perform at every indicated month or operating hour interval, whichever comes first.		Each Use	First Month or 20 Hrs	Every 3 Months or 50 Hrs	Every 6 Months or 100 Hrs	Every Year or 300 Hrs	Refer to Page
ITEM							
Engine oil	Check level	o					7
	Change		o		o		
Air cleaner	Check	o					8
	Clean			o (2)			
	Replace					o	
Spark plug	Check-adjust				o		9
	Replace					o	
Idle speed	Check-adjust					o (3)	9
Valve clearance	Check-adjust					o (3)	Shop manual
Combustion chamber	Clean	After every 500 Hrs. (3)					Shop manual
Zero governor	Check-Clean	Every 2 years or 300 Hrs (Parts replacement if necessary)(3)(4)					Shop manual
Fuel tube Shutoff tube Purge tube	Check	Every 2 years (Replace if necessary) (3)(4)					Shop manual

- (1) For commercial use, log hours of operation to determine proper maintenance intervals.
- (2) Service more frequently when used in dusty areas.
- (3) These items should be serviced by your servicing dealer, unless you have the proper tools and are mechanically proficient. Refer to the Honda shop manual for service procedures.
- (4) Check that there is no crack and damage, and replace if it is abnormal.

Failure to follow this maintenance schedule could result in non-warrantable failures.

REFUELING

Recommended Fuel

Propane	Butane
30%	70%
40%	60%
50%	50%
60%	40%
70%	30%

This engine is certified to operate on LPG only.

The engine may not be able to start at 0°C (32°F) or lower depending on the composition and remaining amount of gas in the LPG cylinder.

Occasionally you may hear a light "spark knock" or "pinging" (metallic rapping noise) while operating under heavy loads. This is no cause for concern.

If spark knock or pinging occurs at a steady engine speed, under normal load, see an authorized Honda servicing dealer.

NOTICE

Running the engine with persistent spark knock or pinging can cause engine damage.

Running the engine with persistent spark knock or pinging is considered misuse, and the Distributor's Limited Warranty does not cover parts damaged by misuse.

ENGINE OIL

Oil is a major factor affecting performance and service life. Use 4-stroke automotive detergent oil that is designed for engines operating on LPG.

Recommended Oil

Use 4-stroke motor oil that meets or exceeds the requirements for API service category SE or later (or equivalent). Always check the API service label on the oil container to be sure it includes the letters SE or later (or equivalent).

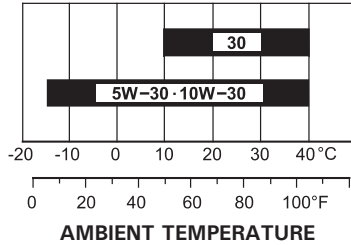

SAE 10W-30 is recommended for general use. Other viscosities shown in the chart may be used when the average temperature in your area is within the indicated range.

Oil Level Check

Check the engine oil level with the engine stopped and in a level position.

1. Remove the oil filler cap/dipstick and wipe it clean.
2. Insert the oil filler cap/dipstick into the oil filler neck as shown, but do not screw it in, then remove it to check the oil level.
3. If the oil level is near or below the lower limit mark on the dipstick, fill with the recommended oil to the upper limit mark (bottom edge of the oil fill hole). Do not overfill.
4. Reinstall the oil filler cap/dipstick.

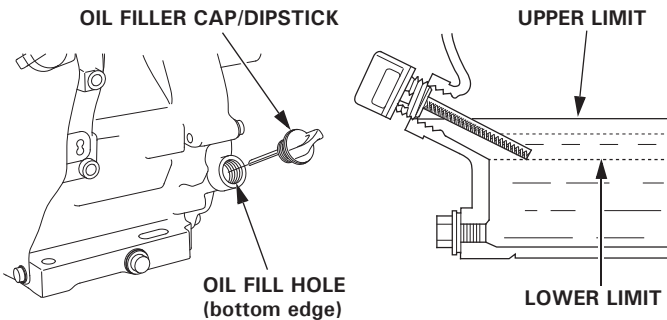

NOTICE

Running the engine with a low oil level can cause engine damage. This type of damage is not covered under the Warranty.

The Oil Alert system (applicable types) will automatically stop the engine before the oil level falls below the safe limit. However, to avoid the inconvenience of an unexpected shutdown, always check the engine oil level before startup.

Oil Change

Drain the used oil when the engine is warm. Warm oil drains quickly and completely.

1. Place a suitable container below the engine to catch the used oil, then remove the oil filler cap/dipstick, oil drain bolt and washer.
2. Allow the used oil to drain completely, then reinstall the oil drain bolt and a new washer, and tighten the oil drain bolt securely.

Please dispose of used motor oil in a manner that is compatible with the environment. We suggest you take used oil in a sealed container to your local recycling center or service station for reclamation. Do not throw it in the trash, pour it on the ground, or pour it down a drain.

3. With the engine in a level position, fill with the recommended oil to the upper limit mark (bottom edge of the oil fill hole) on the dipstick.

Engine oil capacity: GX200 : 0.60 L (0.53 Imp qt)
GX390 : 1.1 L (1.0 Imp qt)

NOTICE

Running the engine with a low oil level can cause engine damage. This type of damage is not covered by the Distributor's Limited Warranty.

The Oil Alert system (applicable types) will automatically stop the engine before the oil level falls below the safe limit. However, to avoid the inconvenience of an unexpected shutdown, fill to the upper limit, and check the oil level regularly.

4. Reinstall the oil filler cap/dipstick and tighten securely.

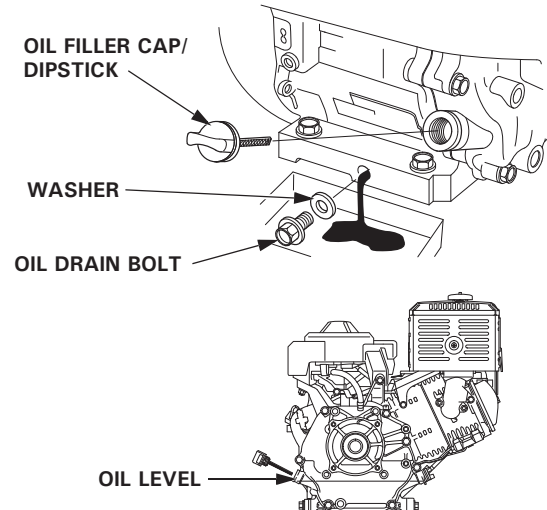

Wash your hands with soap and water after handling used oil.

NOTICE

Please dispose of used motor oil in a manner that is compatible with the environment. We suggest you take it in a sealed container to your local service station for reclamation. Do not throw it in the trash, pour it on the ground, or pour it down a drain.

AIR CLEANER

A dirty air cleaner will restrict air flow to the mixer, reducing engine performance. If you operate the engine in very dusty areas, clean the air filter more often than specified in the MAINTENANCE SCHEDULE (see page 6).

NOTICE

Operating the engine without an air filter, or with a damaged air filter, will allow dirt to enter the engine, causing rapid engine wear. This type of damage is not covered by the Distributor's Limited Warranty.

Inspection

Remove the air cleaner cover and inspect the filter elements. Clean or replace dirty filter elements. Always replace damaged filter elements.

Cleaning

1. Remove the air cleaner cover nut from the air cleaner cover, and remove the cover.
2. Remove the wing nut from the air filter, and remove the filter.
3. Remove the foam air filter element from the paper air filter element.
4. Inspect both air filter elements, and replace them if they are damaged. Always replace the paper air filter element at the scheduled interval (see page 6).
5. Clean the air filter elements if they are to be reused.

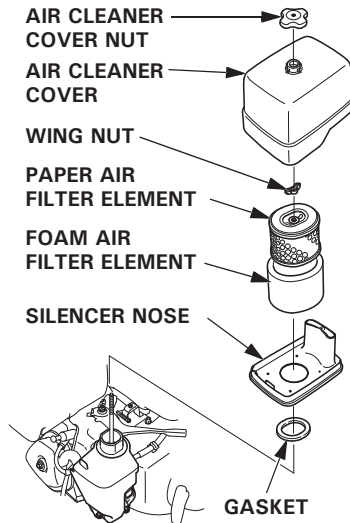

Foam air filter element: Clean in warm soapy water, rinse, and allow to dry thoroughly. Or clean in non-flammable solvent and allow to dry. Dip the filter element in clean engine oil, then squeeze out all excess oil. The engine will smoke when started if too much oil is left in the foam.

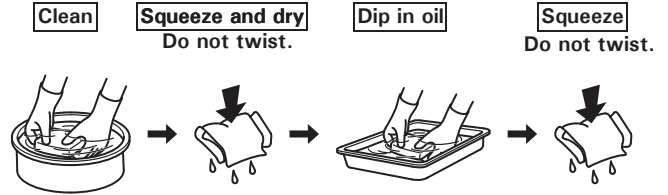

6. Wipe dirt from the inside of the air cleaner case and cover using a moist rag. Be careful to prevent dirt from entering the air duct that leads to the mixer.
7. Place the foam air filter element over the paper air filter element, and reinstall the assembled air filter. Be sure the gasket is in place beneath the air filter. Tighten the wing nut securely.
8. Install the air cleaner cover, and tighten the air cleaner cover nut securely.

Paper air filter element: Tap the filter element several times on a hard surface to remove dirt, or blow compressed air [not exceeding 207 kPa (2.1 kgf/cm²)] through the filter element from the inside. Never try to brush off dirt; brushing will force dirt into the fibers.

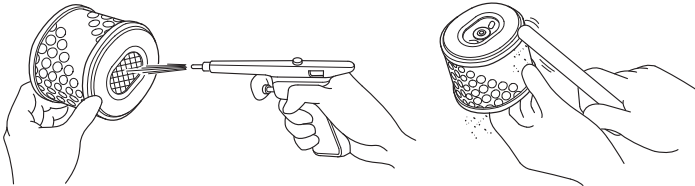

SPARK PLUG

Recommended Spark Plugs: GX200:BPR6ES-5 (NGK)
GX390:BP6ES (NGK)

The recommended spark plug has the correct heat range for normal engine operating temperatures.

NOTICE

An incorrect spark plug can cause engine damage.

If the engine has been running, let it cool before servicing the spark plug.

For good performance, the spark plug must be properly gapped and free of deposits.

1. Disconnect the spark plug cap, and remove any dirt from around the spark plug area.
2. Remove the spark plug with a spark plug wrench.
3. Inspect the spark plug. Replace it if damaged or badly fouled, if the sealing washer is in poor condition, or if the electrode is worn.

SPARK PLUG WRENCH

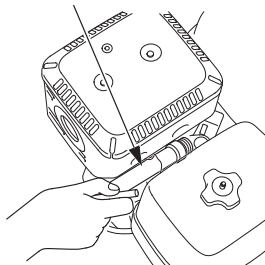

4. Measure the spark plug electrode gap with a wire-type feeler gauge. Correct the gap, if necessary, by carefully bending the side electrode. The gap should be:
GX200:0.4–0.5 mm
(0.016–0.020 in)
GX390:0.7–0.8 mm
(0.028–0.031 in)

SIDE ELECTRODE

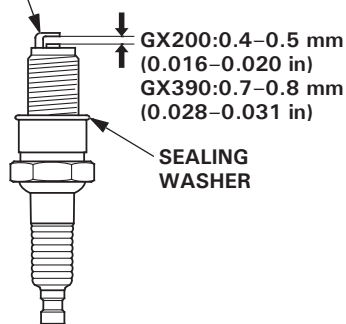

5. Install the spark plug carefully, by hand, to avoid cross-threading.
6. After the spark plug is seated, tighten with a spark plug wrench to compress the sealing washer.

When installing a new spark plug, tighten 1/2 turn after the spark plug seats to compress the washer.

When reinstalling the original spark plug, tighten 1/8–1/4 turn after the spark plug seats to compress the washer.

TORQUE: 18 N·m (1.8 kgf·m, 13 lbf·ft)

NOTICE

A loose spark plug can overheat and damage the engine. Overtightening the spark plug can damage the threads in the cylinder head.

7. Attach the spark plug cap to the spark plug.

IDLE SPEED

Adjustment

1. Start the engine outdoors, and allow it to warm up to operating temperature.
2. Move the throttle lever to its minimum position.
3. Turn the throttle stop screw to obtain the standard idle speed.

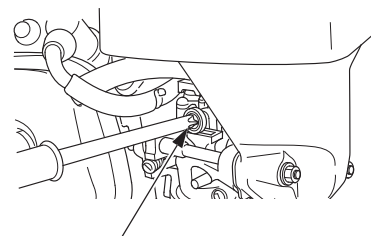

THROTTLE STOP SCREW

Standard idle speed: GX200 : 1,400 + 200 min⁻¹(rpm)
- 150 min⁻¹(rpm)
GX390 : 1,400 ± 150 min⁻¹(rpm)

HELPFUL TIPS & SUGGESTIONS

STORING YOUR ENGINE

Storage Preparation

Stop the engine and close the LPG supply valve. For Indonesia models, release the low pressure regulator before removing the hose.

Proper storage preparation is essential for keeping your engine trouble-free and looking good. The following steps will help to keep rust and corrosion from impairing your engine's function and appearance, and will make the engine easier to start when you use it again.

Cleaning

If the engine has been running, allow it to cool for at least half an hour before cleaning. Clean all exterior surfaces, touch up any damaged paint, and coat other areas that may rust with a light film of oil.

NOTICE

Using a garden hose or pressure washing equipment can force water into the air cleaner or muffler opening. Water in the air cleaner will soak the air filter, and water that passes through the air filter or muffler can enter the cylinder, causing damage.

Engine Oil

1. Change the engine oil (see page 7).

Engine Cylinder

1. Remove the spark plug.
2. Pour a teaspoon 5–10 cm³ of clean engine oil into the cylinder.
3. Pull the starter grip several times to distribute the oil in the cylinder.
4. Reinstall the spark plug.
5. Pull the starter grip slowly until resistance is felt. This will close the valves so moisture cannot enter the engine cylinder. Return the starter grip gently.
6. Cover the engine to keep out dust.

Storage Precautions

Select a well ventilated storage area away from any appliance that operates with a flame, such as a furnace, water heater, or clothes dryer. Also avoid any area with a spark-producing electric motor, or where power tools are operated.

If possible, avoid storage areas with high humidity, because that promotes rust and corrosion.

Keep the engine level in storage. Tilting can cause oil leakage.

With the engine and exhaust system cool, cover the engine to keep out dust. A hot engine and exhaust system can ignite or melt some materials. Do not use a plastic sheet as a dust cover.

A nonporous cover will trap moisture around the engine, promoting rust and corrosion.

Removal from Storage

Check your engine as described in the *BEFORE OPERATION CHECKS* section of this manual (see page 3).

If the cylinder was coated with oil during storage preparation, the engine will smoke briefly at startup. This is normal.

TRANSPORTING

If the engine has been running, allow it to cool for at least 15 minutes before loading the engine-powered equipment on the transport vehicle. A hot engine and exhaust system can burn you and can ignite some materials.

Before you transport the engine, the LPG hose must be disconnected.

You must disconnect the LPG hose.

TAKING CARE OF UNEXPECTED PROBLEMS

ENGINE WILL NOT START

Possible Cause	Correction
Engine switch OFF.	Turn engine switch to ON position.
Out of fuel.	Refuel (p. 6).
Engine oil level low (Oil Alert models).	Fill with the recommended oil to the proper level (p. 7).
Spark plug faulty, fouled, or improperly gapped.	Gap or replace spark plug (p. 9).
Mixer malfunction, ignition malfunction, valves stuck, etc.	Take engine to your servicing dealer, or refer to shop manual.

ENGINE LACKS POWER

Possible Cause	Correction
Filter element (s) restricted.	Clean or replace filter element (s) (p. 8).
Fuel quality or pressure is poor.	Use a reliable LPG source.
Mixer malfunction, ignition malfunction, valves stuck, etc.	Take engine to your servicing dealer, or refer to shop manual.

TECHNICAL INFORMATION

Serial Number Location

Record the engine serial number in the space below. You will need this information when ordering parts and when making technical or warranty inquiries.

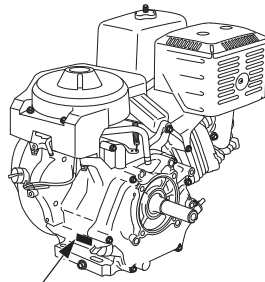

SERIAL NUMBER & ENGINE TYPE LOCATION

Engine serial number: _____

Engine type: _____

Date Purchased: ____ / ____ / ____

Remote Control Linkage

The throttle lever is provided with hole for optional cable attachment. The following illustrations show installation example for a solid wire cable and for a flexible, braided wire cable. If using a flexible, braided wire cable, add a return spring as shown.

It is necessary to loosen the throttle lever friction nut when operating the throttle with a remote-mounted control.

REMOTE THROTTLE LINKAGE

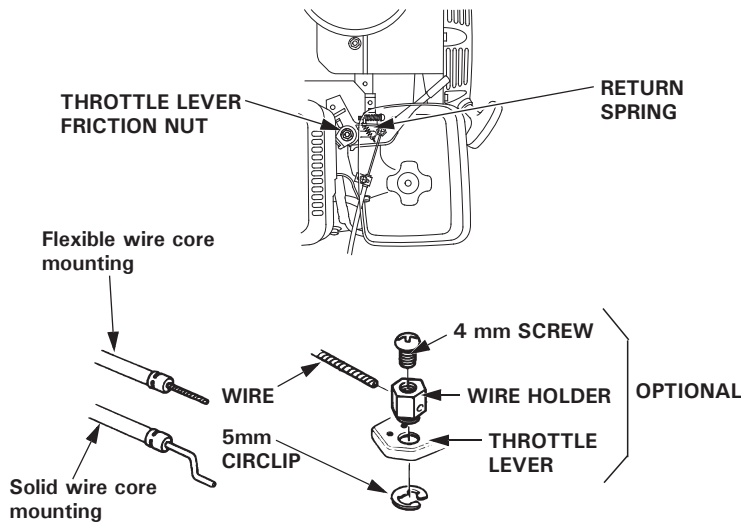

High Altitude Operation

The LPG fueled engine does not require any modifications for high-altitude operation. However, performance and horse power will decrease at high altitudes.

Specifications

GX200 (PTO shaft type Q)

Length × Width × Height	321 × 376 × 335 mm (12.6 × 14.8 × 13.2 in)
Dry mass [weight]	16.0 kg (35.3 lbs)
Engine type	4-stroke, overhead valve, single cylinder
Displacement [Bore × Stroke]	196 cm ³ (12.0 cu-in) [68.0 × 54.0 mm (2.7 × 2.1 in)]
Net power (in accordance with SAE J1349*)	4.1 kW (5.6 PS)/3,600 min ⁻¹ (rpm)
Max. Net torque (in accordance with SAE J1349*)	12.4 N·m (1.26 kgf·m, 9.1 lbf·ft)/ 2,500 min ⁻¹ (rpm)
Engine oil capacity	0.60 L (0.53 Imp qt)
Cooling system	Forced air
Ignition system	Transistor magneto
PTO shaft rotation	Counterclockwise

GX390 (PTO shaft type Q)

Length × Width × Height	406 × 460 × 448 mm (16.0 × 18.1 × 17.6 in)
Dry mass [weight]	30.7 kg (67.7 lbs)
Engine type	4-stroke, overhead valve, single cylinder
Displacement [Bore × Stroke]	389 cm ³ (23.7 cu-in) [88.0 × 64.0 mm (3.5 × 2.5 in)]
Net power (in accordance with SAE J1349*)	7.9 kW (10.7 PS)/3,600 min ⁻¹ (rpm)
Max. Net torque (in accordance with SAE J1349*)	24.0 N·m (2.45 kgf·m, 17.7 lbf·ft)/ 2,500 min ⁻¹ (rpm)
Engine oil capacity	1.1 L (1.0 Imp qt)
Cooling system	Forced air
Ignition system	CDI magneto
PTO shaft rotation	Counterclockwise

* The power rating of the engine indicated in this document is the net power output tested on a production engine for the engine model and measured in accordance with SAE J1349 at 3,600 min⁻¹(rpm) (Net Power) and at 2,500 min⁻¹(rpm) (Max. Net Torque). Mass production engines may vary from this value. Actual power output for the engine installed in the final machine will vary depending on numerous factors, including the operating speed of the engine in application, environmental conditions, maintenance, and other variables.

Tuneup Specifications

GX200

ITEM	SPECIFICATION	MAINTENANCE
Spark plug gap	0.4–0.5 mm (0.016–0.020 in)	Refer to page: 9
Idle speed	1,400 + 200 min ⁻¹ (rpm) –150 min ⁻¹ (rpm)	
Valve clearance (cold)	IN: 0.15 ± 0.02 mm EX: 0.20 ± 0.02 mm	See your authorized Honda dealer
Other specifications	No other adjustments needed.	

GX390

ITEM	SPECIFICATION	MAINTENANCE
Spark plug gap	0.7–0.8 mm (0.028–0.031 in)	Refer to page: 9
Idle speed	1,400 ± 150 min ⁻¹ (rpm)	
Valve clearance (cold)	IN: 0.15 ± 0.02 mm EX: 0.20 ± 0.02 mm	See your authorized Honda dealer
Other specifications	No other adjustments needed.	

Wiring Diagrams

GX200

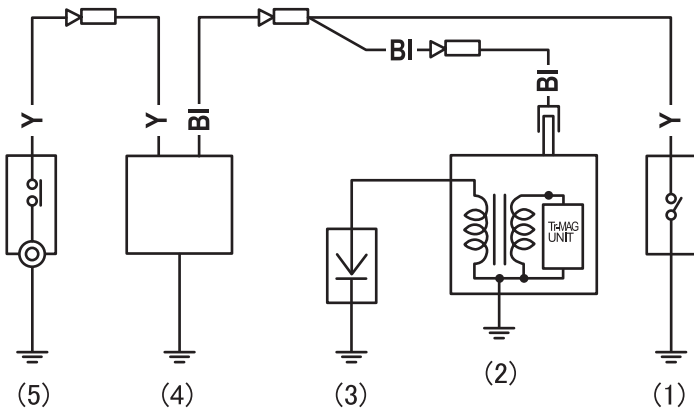

	IGN	EARTH
OFF ○ ●	○ ○	○ ○
ON ○		

GX390

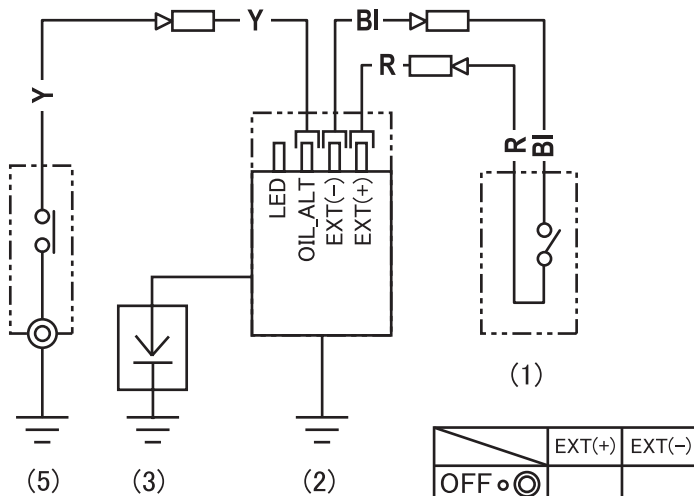

	EXT(+)	EXT(-)
OFF ○ ●		
ON ○	○ ○	○ ○

- (1) ENGINE SWITCH
- (2) IGNITION COIL
- (3) SPARK PLUG
- (4) OIL ALERT UNIT
- (5) OIL LEVEL SWITCH

BI	Black
Y	Yellow
R	Red

CONSUMER INFORMATION

DISTRIBUTOR/DEALER LOCATOR INFORMATION

Visit our website: <http://www.honda-engines-eu.com>

CUSTOMER SERVICE INFORMATION

Servicing dealership personnel are trained professionals. They should be able to answer any question you may have. If you encounter a problem that your dealer does not solve to your satisfaction, please discuss it with the dealership's management. The Service Manager, General Manager, or Owner can help. Almost all problems are solved in this way.

If you are dissatisfied with the decision made by the dealership's management, contact the Honda Office as shown.

< Honda's Office >

When you write or call, please provide this information:

- Equipment manufacturer's name and model number that the engine is mounted on
- Engine model, serial number, and type (see page 11)
- Name of dealer who sold the engine to you
- Name, address, and contact person of the dealer who services your engine
- Date of purchase
- Your name, address and telephone number
- A detailed description of the problem

Honda Motor Europe Logistics NV.

European Engine Center

<http://www.honda-engines-eu.com>

Please contact the Honda distributor in your area for assistance.

HONDA

WILDLAND

SERIES



Fire Fighting Water Pumps

FIRE PUMP

WS1565H

USER MANUAL

BEPOWEREQUIPMENT

.COM

BE

Introduction

4 Using the Operators Manual

Product Identification

5 Water Pump

Safety

6 Safety Rules & Warnings

6 Hazard Symbols & Meanings

Water Pump Components

11 Component Chart

Assembly

12 Connecting Hose to Pump

13 Attaching Suction Hose to Strainer Basket

13 Connecting Discharge Hose

Operation

14 What is “Head”

15 Moving the Water Pump to a Safe Location

15 Priming the Water Pump

16 Placing the Strainer Basket in Water Source

Starting The Water Pump

17 Starting the Pump & First-Time Use

Stopping The Water Pump

19 Stopping the Water Pump

19 Draining & Flushing the Water Pump



WARNING
ADVERTENCIA • AVERTISSEMENT

Cancer and Reproductive Harm
Cáncer y Daño Reproductivo
Cancer et dommages à la reproduction

www.P65Warnings.ca.gov



INTRODUCTION



Attention: Read through the complete manual prior to the initial use of your water pump

Using the Operator's manual

The operating manual is an important part of your water pump. It should be read thoroughly before initial use and referred to often to make sure adequate safety and service concerns are being addressed.

Reading the owner's manual thoroughly will help avoid any personal injury or damage to your machine. By knowing how best to operate this machine you will be better positioned to show others who may also operate the unit.

This manual contains information for the complete range of water pumps, and is placed in order starting from the safety requirements to the operating functions of your machine. You can refer back to the manual at any time to help troubleshoot any specific operating functions, so store it with the machine at all times.

PRODUCT IDENTIFICATION



Record Identification Numbers

WATER PUMP

If you need to contact an Authorized Dealer or Customer Service line for information on servicing, always provide the product model and identification numbers.

You will need to locate the model and serial number for the machine and record the information in the places provided below.

Date of Purchase:

Dealer Name:

Dealer Phone:

Product Identification Numbers

Model Number:

Serial Number:

Engine

Horse Power:

Save these Instructions

Safety Rules



This is the safety alert symbol. It is used to alert you to potential personal injury hazards. Obey all safety messages that follow this symbol to avoid possible injury or death.

The safety alert symbol () is used with a signal word (DANGER, CAUTION, WARNING), a pictorial and/or a safety message to alert you to hazards.

DANGER indicates a hazard which, if not avoided, will result in death or serious injury.

WARNING indicates a hazard which, if not avoided, could result in death or serious injury.

CAUTION indicates a hazard which, if not avoided, might result in minor or moderate injury.

NOTICE indicates a situation that could result in equipment damage.

Follow safety messages to avoid or reduce the risk of injury or death.

Hazard Symbols and Meanings



EXPLOSION



FIRE



ELECTRIC SHOCK



KICKBACK



HOT SURFACE



TOXIC FUMES



MOVING PARTS







SLIPPERY





READ MANUAL

 WARNING	
	DO NOT ATTACK THE FIRE LINE WITH THIS PUMP
<ul style="list-style-type: none"> • Not to be used to fight major forest fires. 	

 WARNING	
	<p>Running engine gives off carbon monoxide, an odorless, colorless, poison gas.</p> <p>Breathing carbon monoxide can cause headaches, fatigue, dizziness, vomiting, confusion, seizures, nausea, fainting or death.</p>
<ul style="list-style-type: none"> • Operate water pump ONLY outdoors. • Keep exhaust gas from entering a confined area through windows, doors, ventilation intakes, or other openings. • DO NOT start or run engine indoors or in an enclosed area, even if windows and doors are open. 	

 WARNING	
	Use of water pump can create puddles and slippery surfaces.
<ul style="list-style-type: none"> • Operate water pump from a stable surface. • The area should have adequate slopes and drainage to reduce the possibility of a fall due to slippery surfaces. 	

 WARNING	
 	Unintentional sparking can result in fire or electric shock.
<p>When Adjusting or Making Repairs to Your Water Pump</p> <ul style="list-style-type: none"> • Disconnect the spark plug wire from the spark plug and place the wire where it cannot contact spark plug. <p>When Testing for Engine Spark</p> <ul style="list-style-type: none"> • Use an approved spark plug tester. • DO NOT check for sparks with spark plug removed. 	

 **WARNING**



Fuel and its vapors are extremely flammable and explosive.

Fire or explosion can cause severe burns or death.

When Adding or Draining Fuel

- Turn water pump OFF and let it cool for at least 2 minutes before removing fuel cap. Loosen cap slowly to relieve pressure in tank.
- Fill or drain fuel tank outdoors.
- DO NOT overfill tank. Allow space for fuel expansion.
- If fuel spills, wait until it evaporates before starting engine.
- Keep fuel away from sparks, open flames, pilot lights, heat, and other ignition sources.
- DO NOT light a cigarette or smoke.

When Starting Equipment

- Ensure spark plug, muffler, fuel cap, and air cleaner are in place.
- DO NOT crank engine with spark plug removed.

When Operating Equipment



- DO NOT pump flammable liquids, such as fuel or fuel oils.
- This water pump is not for use in mobile equipment or marine applications.
- DO NOT tip engine or equipment at angle which causes fuel to spill.
- Secure water pump. Loads from hoses may cause tipover.



When Transporting or Repairing Equipment



- Transport/repair with fuel tank EMPTY or with fuel shutoff valve OFF.
- Disconnect spark plug wire.

When Storing Fuel or Equipment with Fuel in Tank

- Store away from furnaces, stoves, water heaters, clothes dryers, or other appliances that have pilot light or other ignition source because they can ignite fuel vapors.

 WARNING	
	<p>Starter cord kickback (rapid retraction) can result in bodily injury. Kickback will pull hand and arm toward engine faster than you can let go.</p> <p>Broken bones, fractures, bruises, or sprains could result.</p> <p>Keep hands and body clear from discharge of pump.</p>
<ul style="list-style-type: none"> • When starting engine, pull cord slowly until resistance is felt and then pull rapidly to avoid kickback. • Secure discharge hose to avoid whipping. 	

 WARNING	
 	<p>Contact with muffler area can result in serious burns.</p> <p>Exhaust heat/gases can ignite combustibles, structures or damage fuel tank causing a fire.</p>
<ul style="list-style-type: none"> • DO NOT touch hot parts and AVOID hot exhaust gases. • Allow equipment to cool before touching. • Keep at least 5 feet (1.5 m) of clearance on all sides of pressure washer including overhead. 	

 WARNING	
	<p>Starter and other rotating parts can entangle hands, hair, clothing, or accessories.</p>
<ul style="list-style-type: none"> • NEVER place hands or body parts inside of running pump or hoses. • Never operate water pump without protective housing or covers. • DO NOT wear loose clothing or anything that may be caught in the starter or other rotating parts. • Tie up long hair and remove jewelry. 	



CAUTION

Excessively high operating speeds increase risk of injury and damage to water pump.

Excessively low speeds impose a heavy load.

- DO NOT tamper with the governed speed.
- DO NOT modify the water pump.
- DO NOT allow unqualified persons or children to operate or service water pump.

NOTICE

Improper treatment of water pump can damage it and shorten its life.

- If you have questions about intended use, ask dealer or contact nearest authorized dealer.
- Be sure pump chamber is filled with water before starting the engine. Never run pump without priming.
- Use a non-collapseable hose on the suction side of the hose.
- Use water pump only for intended uses.
- Pumping sea water, beverages, acids, chemical solutions, or any other liquid that promotes corrosion can damage the pump.
- Ensure all connections are air tight.
- DO NOT obstruct the suction or discharge hose in any way.
- NEVER operate pump without strainer basket connected to end of suction hose.
- NEVER allow vehicles to drive over hoses. If a hose must be positioned across a roadway, use planking on each side of hose to allow vehicles to pass over without obstructing or collapsing hose.
- Anchor pump to avoid equipment movement.
- Keep equipment away from edge of river or lake where it could cause the bank to collapse.
- DO NOT insert any objects through cooling slots.
- NEVER operate units with broken or missing parts, or without protective housing or covers.
- DO NOT by-pass any safety device on this machine.
- NEVER move machine by pulling on hoses. Use frame on unit.
- Check fuel system for leaks or signs of deterioration, such as chafed or spongy hose, loose or missing clamps, or damaged tank or cap. Correct all defects before operating water pump.

WATER PUMP COMPONENTS



Your unit may differ from the model shown below. For specific model information, please visit our website: BEPOWEREQUIPMENT.COM

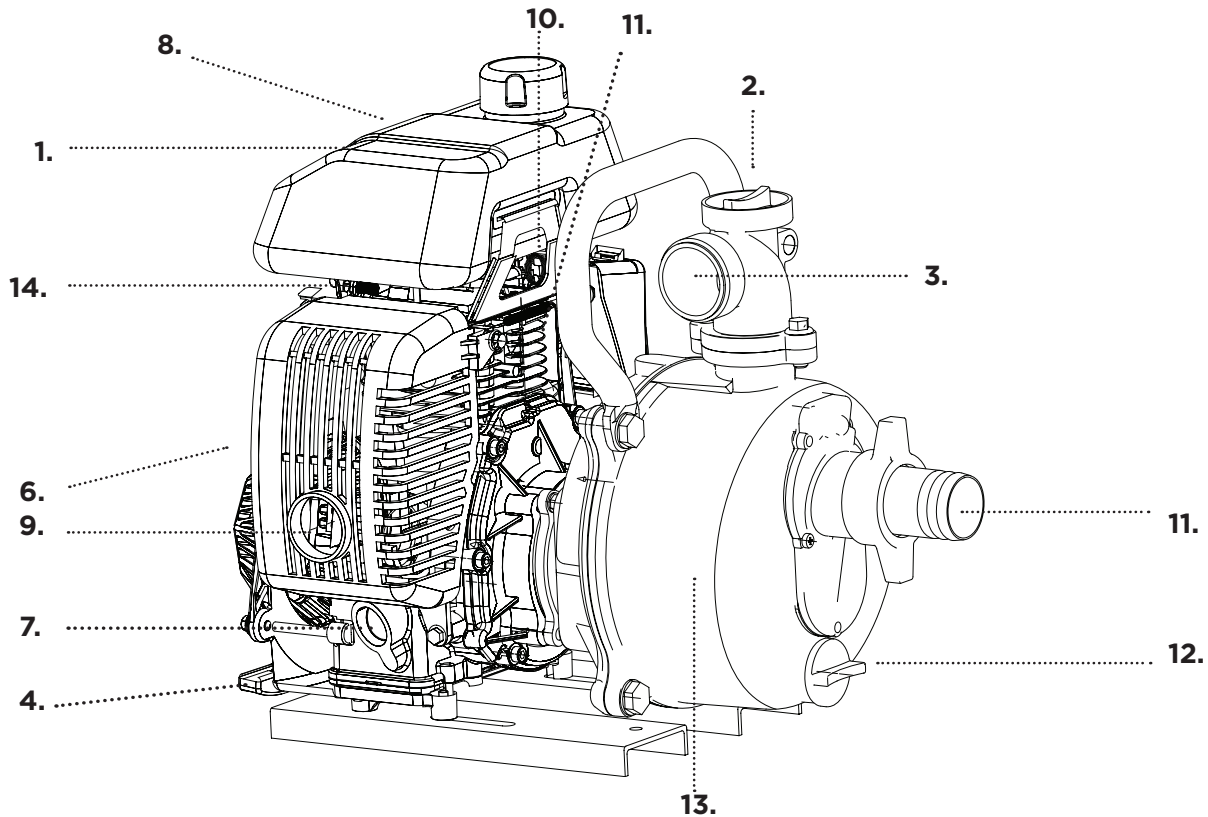

1. **Fuel Tank** Fill tank with regular unleaded fuel. Always leave room for fuel expansion.
2. **Priming Plug** Fill pump with water here to prime pump before starting.
3. **Discharge Outlet** Connect discharge hose here.
4. **Choke Lever** Prepares a cold engine for starting.
5. **Air Cleaner** Protects engine by filtering dust and debris out of intake air.
6. **Recoil Starter** Used for starting the engine manually.
7. **Engine Speed Lever** Used to adjust engine speed to control pump output.
8. **On/Off Switch** Set this switch to "On" before using recoil starter. Set switch to "Off" to stop a running engine.
9. **Oil Drain** Drain engine oil here.
10. **Oil Fill** Check and add engine oil here.
11. **Suction Inlet** Connect reinforced suction hose here.
12. **Water Drain Plug** Remove to drain water from pump and flush internal components with clean water.
13. **Pump Chamber** Be sure to fill with water before starting.
14. **Fuel Shutoff Valve** Used to turn fuel supply on and off to engine.

Item Not Shown:

Strainer Basket Used to limit passage of abrasive materials into the pump.

Your water pump requires some set up and is ready for use after it has been properly serviced with the recommended oil and fuel.

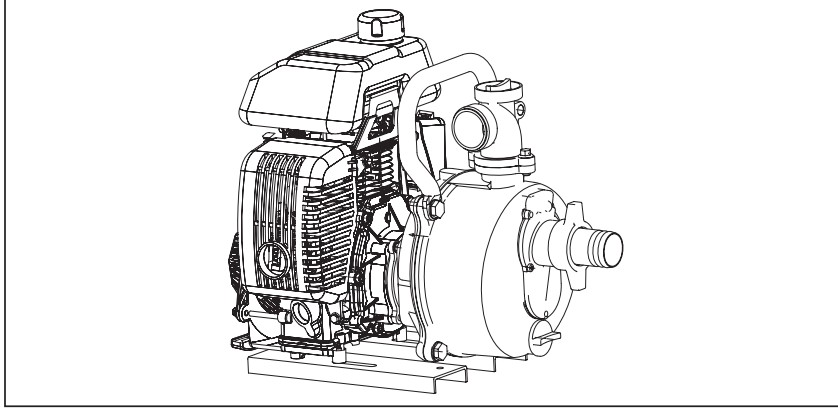

Attach Suction Hose to Strainer Basket

1. Slide hose clamp over hose. Attach open end of suction hose to strainer hose barb. Tighten hose clamp securely. **Please note that this item is not included with all models.**

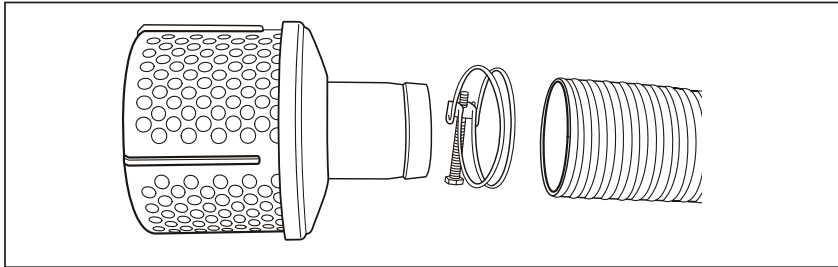

Connect Suction Hose (Mandatory)

Attach Suction Hose by connecting camlocks.

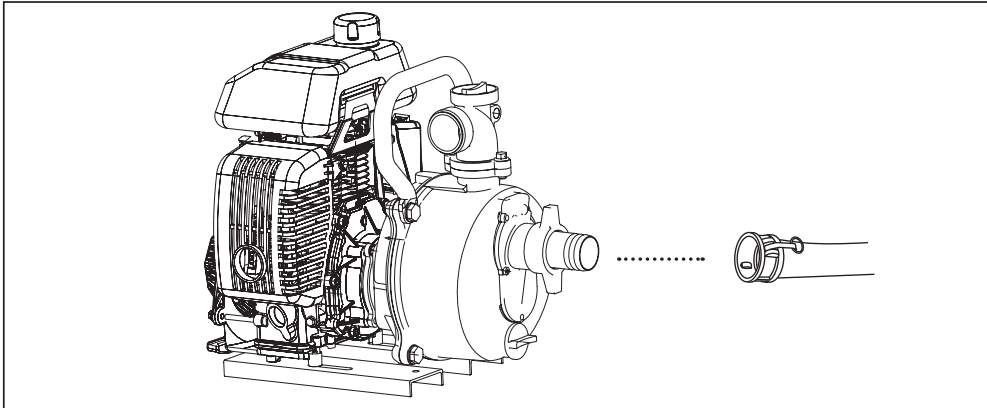

Connect Discharge Hose (Optional)

If desired, use a commercially available hose. DO NOT use a hose with an inside diameter smaller than the pump's discharge port size.

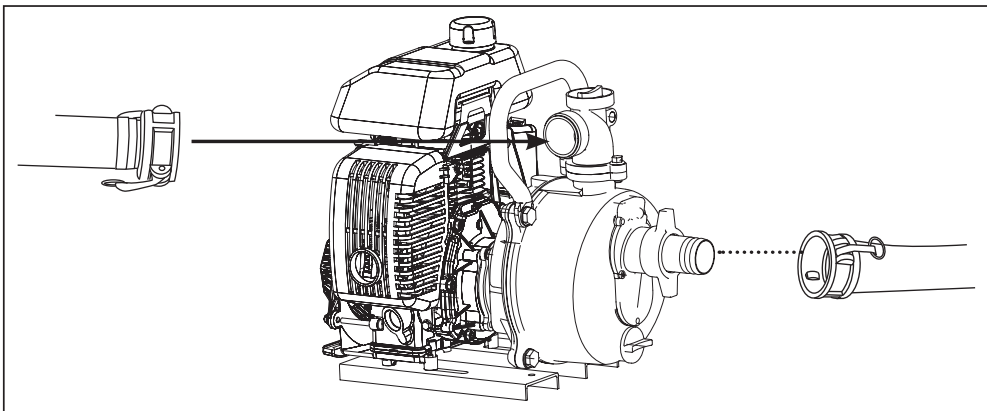

What is “Head”?

Head refers to the height of a column of water that can be delivered by the discharge of the pump.

Suction Head is the vertical distance between the center of the pump and the surface of the liquid on the suction side of the pump. May also be referred to as “suction lift”. The atmospheric pressure of 14.7 psi at sea level limits suction head lift to less than approximately 26 feet for any pump.

Discharge Head is the vertical distance between the pump’s discharge port and the point of discharge, which is the liquid surface if the hose is submerged or pumping into the bottom of a tank.

Total Head is the sum of the suction head value plus the discharge head value.

As water pumping height increases, pump output decreases. The length, type, and size of the suction and discharge hoses can also significantly affect pump output.



It is important for the suction operation to be the shorter part of the total pumping action. This will decrease the priming time and improve pump performance by increasing the discharge head.

Suction head is a maximum of 25 feet and discharge head should be a maximum of 81 feet. Total head can not be more than 106 feet as shown on next page.

Move Water Pump to Safe Operating Location

For the best pump performance, place the pump on a flat, level surface as close as possible to the water to be pumped. Secure water pump to avoid tipover or tilting. Use hoses that are no longer than necessary.

IMPORTANT: Direct open end of discharge hose away from home, electrical devices or anything not desired to get wet.

 WARNING	
 	<p>Fuel and its vapors are extremely flammable and explosive.</p> <p>Fire or explosion can cause severe burns or death.</p>
<ul style="list-style-type: none">• This water pump is not for use in mobile equipment or marine applications• DO NOT tip engine or equipment at angle which causes fuel to spill.• Secure water pump. Loads from hoses may cause tip over.	

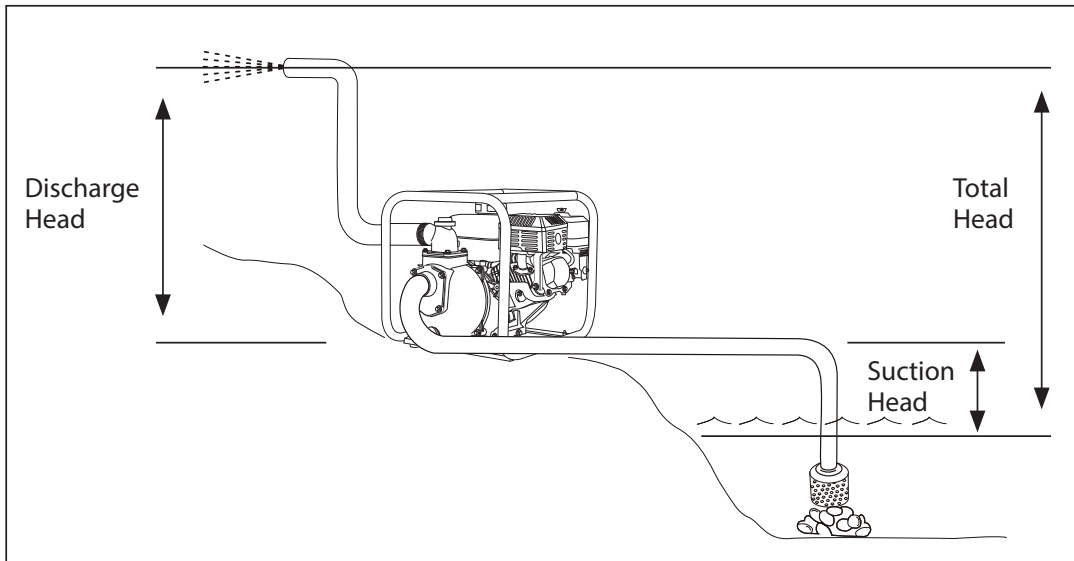

Prime the Water Pump

1. Remove priming plug from top of pump.
2. Fill pump with clean, clear water up to top of discharge outlet.
3. Replace priming plug.

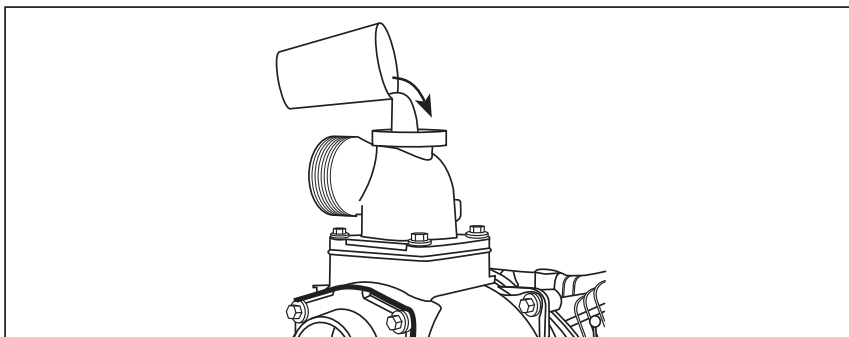

NOTICE

Improper treatment of water pump can damage it and shorten its life.

- Be sure chamber is filled with water before starting the engine.
- NEVER run pump without priming

Placing Strainer Basket Into Water Source

Place strainer basket into water to be pumped. Basket must be fully immersed.

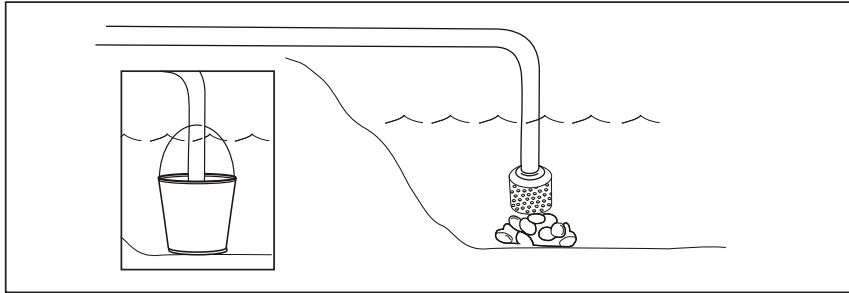

NOTICE

Improper treatment of water pump can damage it and shorten its life.

- NEVER operate pump without strainer connected to end of suction hose.
- Keep strainer out of sand or silt, place in bucket or on stones.
- DO NOT let pump run dry or damage to seals may result.

STARTING THE WATER PUMP



Starting the Water Pump

Use the following start instructions:

1. Fill Engine with Oil, SAE 10W30

2. Make sure unit is on a flat, level surface and pump chamber is primed.
3. Turn fuel valve (1) to “On” position. The fuel valve handle will be vertical (pointing toward the ground).

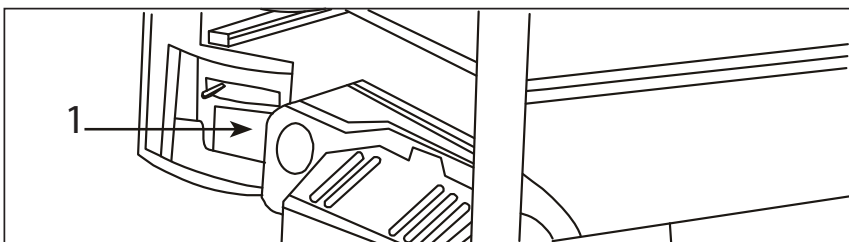

4. Push on/off switch (2) to “On” position.
5. Move engine speed lever (3) to “Fast” () position.

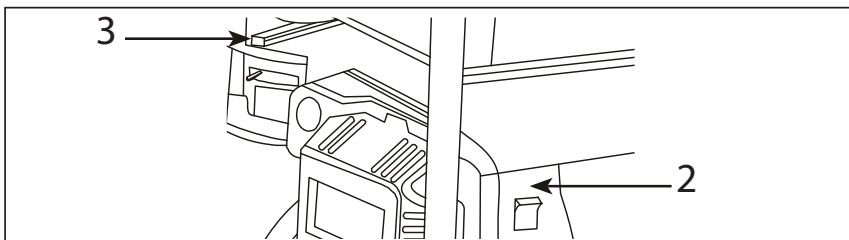

6. Move choke lever (4) to “On” position.

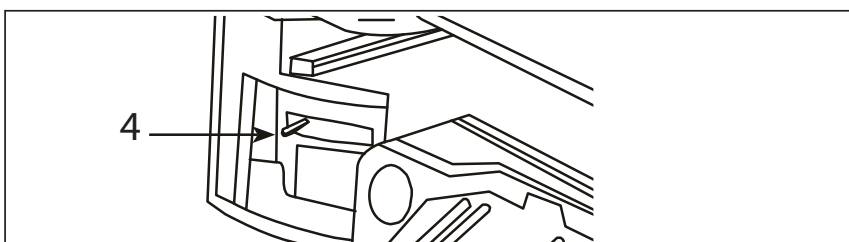

7. Grasp recoil handle and pull slowly until slight resistance is felt. Then pull handle rapidly to overcome compression, prevent kickback and start engine.

WARNING



Starter cord kickback (rapid retraction) can result in bodily injury. Kickback will pull hand and arm toward engine faster than you can let go.

Broken bones, fractures, bruises, or sprains could result.

- When starting engine, pull cord slowly until resistance is felt and then pull rapidly to avoid kickback.





STARTING THE WATER PUMP

IMPORTANT: If excessive fuel is present in the air/fuel mixture causing a “flooded” condition, move choke lever to “Run” position and pull handle repeatedly until engine starts.

8. Move choke lever to “Run” position a short distance at a time over several seconds in warm weather or minutes in cold weather. Let engine run smoothly before each change. Operate with choke in “Run” position.



IMPORTANT: It may take a few minutes for water pump to begin pumping water.

 WARNING	
 	Contact with muffler area can result in serious burns. Exhaust heat/gases can ignite combustibles, structures or damage fuel tank, causing a fire.
<ul style="list-style-type: none">• DO NOT touch hot parts and AVOID hot exhaust gases.• Allow equipment to cool before touching.• Keep at least 5 feet (1.5 m) of clearance on all sides of pressure washer including overhead.	

Pump output is controlled by adjusting engine speed. Moving the engine speed lever in the “Fast” direction will increase pump output, and moving the engine speed lever in the “Slow” direction will decrease pump output.

Stopping the Water Pump

1. Move engine speed lever to “Slow” position.
2. Push on/off switch to “Off” position.
3. Turn fuel valve to “Off” position.

 WARNING	
	Backfire, fire or engine damage could occur.
• DO NOT stop engine by moving choke control to “Choke” position.	

Drain and Flush Water Pump

1. Disconnect and drain suction and discharge hoses.
2. Remove drain plug at bottom of pump.

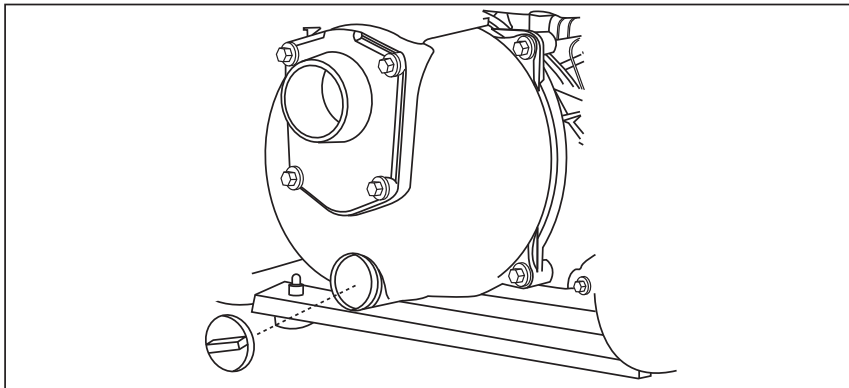

3. Remove primer plug from top of pump and flush internal components of pump with clean water.

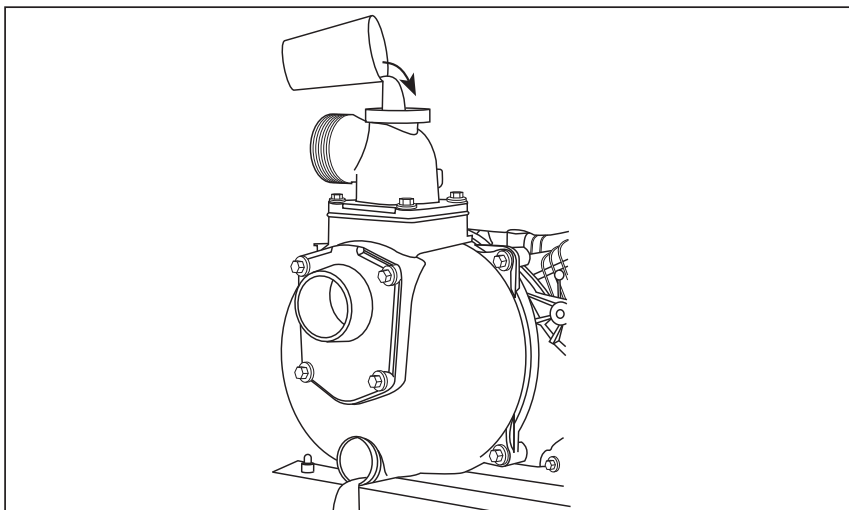

4. Replace both plugs and finger tighten.

BE

THE POWER YOU NEED.

**If you need assistance with the assembly
or operation of your Water Pump please call**

1-866-850-6662



TRAILER AXLE (8K-16K)
OWNER'S MANUAL

Table of Contents

Introduction	3
Safety Information	3
Break-In Period For Electric Drum Brakes	4
Trailer Axle Brake Inspections	4
Recommended Component Inspection Periods	5
Hubs/Drums/Bearing	5
Brake Hub Removal	5
Clean Brake Drum	6
Brake Drum Inspection	7
Disc Brake Rotor and Pad Inspection	7
Disc Brake Caliper	7
Bearing Inspection - Inner and Outer	7
Bearing Cup Inspection and Removal	8
Brake/Idler Hub Installation	9
Inner Bearing Cone and Grease Seal Installation	9
Bearing Lubrication - Oil	11
Oil Seal	12
Periodic Bearing Inspection	12
Spindle Nut Adjustment	12
Disc Brake Option	12
Disc Brake Pads	12
Disc Brake Caliper	12
Electric Brakes	13
How to Use Lippert Electric Brakes Properly	13
General Maintenance - Electric Brakes	14
Brake Adjustment	14
Lubricate Brakes	14
Clean and Inspect Brakes	14
Magnets	15
Shoes and Linings	15
Hub Replacement	16
Axle and Suspension Installation	16
Suspension Systems	16
Double-Eye Leaf Springs	16
Slipper Leaf Springs - Optional	17
Torsion Suspension System	18
Inspection	18
Equalizer Replacement	19
Suspension Replacement	19
Wheels	19
Wheel Selection	19
Torque Requirements	20
Tires	21
Introduction to Troubleshooting	22
Troubleshooting	22
Troubleshooting Chart	22
Measuring Voltage	22
Measuring Amperage	22
Amperage Chart	23
Maintenance Schedule	26
Wiring Diagram	27
Pigtail and Coupler Wiring Color Codes	28
Storage	29
Storage Preparation	29
Extended Storage Inspection Procedures	29
Trip Preparation Checklist	29
Limited Warranty	30

Introduction

Combining years of experience in the trailer frame and recreational vehicle industry with the newest and most innovative technology, Lippert introduces the Axle and Running Gear Division.

The following publication is designed to give the customer an easy-to-understand operation and service manual to provide useful and important information. The quality of the Lippert name and the finest materials utilized in the production of the Axles and Running Gear provide you with hubs, brakes, drums and spindles that make trailering and braking the finest in the industry.

Quality comes threefold at Lippert:

1. The finest quality materials.
2. The latest technology and design.
3. The quality standards maintained from materials to final assembly.

For information on the assembly or individual components of this product, please visit:

<https://support.lci1.com/axles-and-suspension>

A QR code on the axle serial number label will also supply access to this online support documentation as well as provide information for OEMs. If using an Android camera phone to scan the label's QR code, it will provide a link to the website in addition to information on serial number, load rating, item number and description, customer and manufacturer purchase information and manufacture date. If using an iPhone, scanning the QR code with its camera will supply only the Lippert website link. A QR code reader app is needed on an iPhone to access the OEM information.



Safety Information



The “WARNING” symbol is a sign that precedes a service, maintenance or operational procedure containing a possible personal safety risk that could result in serious injury or death if stated safety precautions and procedural steps are not followed as set forth in this manual.

⚠️ WARNING

Performing service, repair or routine maintenance work can cause personal injury or death. Use personal protective equipment (PPE) whenever performing service work or routine maintenance. Make sure work space is clean and free of slip or trip hazards.

Always wear eye protection when performing service or maintenance to the vehicle. Other safety equipment to consider would be hearing protection, gloves and possibly a full face shield, depending on the nature of the service.

This manual provides general service and maintenance procedures. Many variables can change the circumstances of the service procedure, e.g., the degree of difficulty involved in the service operation and the ability level of the individual performing the operation. This manual cannot begin to plot out procedures for every possibility, but will provide the general instructions for effectively servicing the vehicle. In the event the skill level required is too high or the procedure too difficult, a certified technician should be consulted before performing the necessary service. Failure to correctly service the vehicle may result in voiding the warranty, inflicting injury or even death. The owner's manual for your trailer may have more procedures for service and maintenance.

Break-In Period For Electric Drum Brakes

NOTE: Brakes should be manually adjusted after the first 200 miles of operation, then periodically every 3,000 miles.

The break-in period is a typical phenomenon with drum brakes and especially electric drum brakes. Electric drum brakes will require a break-in period to achieve full performance. This break-in period applies for new axles and any time new brake shoes and/or magnets are installed as part of regular maintenance. Lippert has found through extensive brake testing that the break-in period for our drum brakes can range from 20 to 50 brake applications.

Brakes can be seated in by applying approximately 8-10 volts to the trailer brakes at an initial speed of 40 mph and allowing the truck/trailer combination to slow down to 20 or 25 mph. For best results do not use truck brakes during this procedure. The trailer brakes will seat in faster by using them to stop both the truck and trailer. The easiest method is to apply the trailer brakes using the manual activation lever located on the in-cab brake controller. Care **MUST** be taken to not overheat the lining material, therefore brake applications conducted at one mile intervals will suffice. The driver should feel a noticeable difference in the brake performance during this period, sometimes in as few as 10 applications. After 50 applications, the brake lining material will be fully cured from the heat and develop close to 100% contact with the brake drum surface.

This break-in period not only seats the shoe lining material but also seats in the brake electromagnets. During the break-in period, the linings will wear at a faster rate than they do after they are seated in.

Trailer Axle Brake Inspections

In general, based on normal activity, trailer brakes should be checked annually or every 36,000 miles, whichever comes first. If above normal trailer activity is experienced, then more frequent brake component inspections are recommended. In the event the braking system encounters symptoms of improper application or failure, immediate inspection and service **MUST** be performed.

Recommended Component Inspection Periods

- Periodic Bearing Inspection - Should be performed annually or every 36,000 miles, whichever comes first.
- Bearing Lubrication Inspection - Should be performed annually unless periodic brake inspections reveal abnormal braking performance.
- Brake Cleaning and Inspection - Should be performed annually or every 36,000 miles, whichever comes first.

Hubs/Drums/Bearing

NOTE: A small amount of residual grease on the outside of a new brake hub is normal. Simply wipe the residual grease off of the brake hub. However, it is not normal for a hub to continue to weep grease after its initial installation. Excess grease can coat brake pads, magnets and braking surfaces inside of the hub, resulting in diminished braking capability. Have the brakes checked by a qualified service provider.

Brake Hub Removal

⚠ WARNING

Always lift the trailer by its frame and never by its axle or suspension. Axle and suspension components are not designed, or rated, for the dead weight, point-of-contact loads that the trailer's frame is. Do not go under the trailer unless it is supported by appropriately rated jack stands. Improperly supported trailers can collapse, causing possible serious personal injury or death.

⚠ WARNING

Wear appropriate personal protective equipment (PPE) when performing service or maintenance operations. Always wear eye protection when servicing trailer axles, brakes, hubs, springs and wheels. Not using PPE may result in serious personal injury or death.

Disassemble the brake hub assembly for inspection, maintenance or service as follows:

1. Make sure trailer is on level ground.
2. Chock tires before beginning wheel disassembly.
 - A. Chocked tires will prevent trailer from rolling while brakes are disengaged during disassembly, cleaning, inspection and assembly operations.
3. Loosen wheel lug nuts before raising the trailer to prevent tire from spinning during lug nut removal.
4. After lug nuts have been loosened, raise the trailer until the tire spins freely.
 - A. Continue to lift and support trailer per manufacturer's requirements.
 - I. Use appropriately rated jack stands.
 - II. Place jack stands under the trailer's frame only.
5. Remove all lug nuts from wheel, then remove wheel from brake hub.
 - A. Set wheel and lug nuts aside for later re-assembly.
 - B. Do not lean removed tire against trailer or any jacks. Leaning a heavy tire against a suspended trailer could cause damage to the outside of the trailer or place undue side pressure against a jack, possibly causing the trailer to become unstable.
6. Prior to brake hub disassembly, create a clean area to place removed parts to prevent possible contamination or damage to removed parts.
7. Remove dust cover from hub by prying its edge out of the hub.
 - A. If servicing a brake drum, remove the lubed dust cap with the installed lubed rubber plug.
 - B. If servicing an idler hub, remove the non-lubed dust cap.
 - C. If brake or idler hub assembly is equipped with oil lubrication, place a drip pan underneath the hub.
 - I. Unscrew oil cap using a 2 1/2" socket wrench.
 - II. Let oil drain into drip pan.
8. Pull cotter pin from spindle (castle) nut and discard.
 - A. The cotter pin is a one-time-use item. Do not re-install removed cotter pin.
9. Remove the spindle nut.

NOTE: Remaining grease on components can act as a mastic. Inspect removed spindle nut for attached spindle washer.

10. If spindle washer did not come off with the spindle nut, inspect the outer bearing. Grease may have allowed the washer to stick to it.
 - A. Remove spindle washer.
11. Pull brake or idler hub off of spindle as follows:
 - A. Make sure brakes have been disengaged.
 - B. To prevent outer bearing cone falling freely from the assembly, place one hand on the backside outer rim of the hub and the other hand over the outside of the hub bore to cover the bearing cone.
 - C. Slightly turn the hub while pulling to free the hub from the spindle.
 - I. The outer bearing cone will want to drop out of the hub. Secure the bearing and place it in the clean, removed part area.
 - II. The inner bearing cone and cup remains installed within the hub, contained by the grease seal, and will not fall out.
 - D. Remove the grease seal from hub bore as follows:
 - I. Set the brake or idler hub aside on a clean, solid surface with the outer bearing cup side facing down.
 - II. Use a seal puller or equivalent to remove grease seal from hub.
 - a. Do not re-install removed seal.
 - b. Discard removed seal.

Clean Brake Drum

Older brake linings may contain asbestos dust, which has been linked to serious or fatal illnesses. Certain precautions MUST be taken when servicing brakes:

WARNING

Potential asbestos dust hazard. Do not use compressed air, a dry brush or dry rag to remove brake dust. Disturbed brake dust can become an airborne irritant that can be inhaled or ingested, causing serious personal illness or death. Wear appropriate personal protective equipment (PPE). Use aerosol brake cleaner to wash brake dust away.

Prior to brake drum inspection, clean the brake drum to remove any brake dust or lubricant film.

1. Avoid creating or breathing any brake dust.
2. Do not machine, file or grind brake linings.
3. Use an aerosol brake cleaner to wash away brake dust.
4. Place a drip pan underneath the brake drum to catch the brake cleaner for proper disposal.
5. Completely wash the entire brake drum, including the backing plate, magnet arm and brake shoes.
6. Inspect brake drum, braking components and backing plate for any remaining pockets of oil, grease or dust.
7. Repeat brake washing step if necessary.
8. Proceed with brake drum inspection.

Brake Drum Inspection

The brake shoes contact the drum's inner surface and the brake magnet contacts the armature. These surfaces are subject to wear and should be inspected periodically.

⚠ CAUTION

Resurfacing procedures can produce metal chips and brake dust that can contaminate the wheel bearings and cause component failure. Make sure that the wheel bearing cavities are clean and free of contamination before reinstalling bearings and seals.

1. The drum's inner surface should be re-machined if wear is more than 0.030" or out of round by more than 0.015".
2. The drum should be replaced if scoring or wear is greater than 0.090".

NOTE: If the brake drum must be re-machined, refer to the Brake Drum Specifications chart for the maximum allowable re-bore inner diameter. If the size of the machined bore diameter exceeds the specified dimension, a new brake drum **MUST** be used.

Brake Drum Specifications	
Drum	Maximum Re-bore Diameter
7"	7.09"
10"	10.09"
12"	12.09"

The inner surface of the brake drum that contacts the brake magnet is the armature surface.

1. If the armature surface is scored or worn unevenly, it should not be machined more than 0.030".
 - A. The magnets should be replaced whenever the armature surface is refaced.
 - B. Similarly, whenever the brake magnet is replaced, the armature surface should be refaced.

Disc Brake Rotor and Pad Inspection

Disc brake pads are a consumable item. Visually inspect disc brake pads every 36,000 miles or 12 months, whichever comes first. Disc brake rotor and brake pad surfaces should be visually checked at the same time. If there are deep grooves on one or both rotor surfaces this is an indication of caliper piston, slider bolt or residual pressure problems. Disc brake rotors should be turned when disc brake pads are replaced. Disc brake pads are available through auto parts stores.

Disc Brake Caliper

If the disc brake caliper mounting bolts are removed to service the brake system, do as follows:

1. Lubricate the inside of the rubber slider bolt caliper bushings.
 - A. The rubber bushings are not compatible with petroleum-based grease.
 - B. Use silicone-based grease only.
2. Apply blue thread locking compound to the threaded area of the caliper mounting bolts.
3. Install caliper mounting bolts. Torque caliper mounting bolts to 40-50 ft-lbs.

Bearing Inspection - Inner and Outer

An inspection of the bearing condition can detect early bearing issues. Upon inspection, bearings should look brand new and can be reassembled and used if in this condition.

NOTE: Bearing cones and cups are not interchangeable after installation. Each bearing **MUST** always be matched with its mating cup. Bearing cones and cups are replaced in matching sets of one cone and one cup.

⚠ WARNING

Wear personal protective equipment (PPE) when using caustic materials. Aerosol, liquid and oil-based paste materials can present splash hazards and skin contact environments that can result in serious adverse eye and skin irritations. Follow all recommended safety precautions when using such materials.

1. Wash all grease and oil from the bearing cones using a suitable solvent.
2. Dry bearing cones with a clean, lint-free cloth.
3. Inspect bearing cone cages and rollers for any pitting, spalling, corrosion, flat spots, abnormal condition or discoloration.
 - A. If any of these imperfections are present, then the bearing cone and cup (race) **MUST** be replaced at the same time.
 - B. Bearings are available at auto part stores.
 - I. See Components pages for part numbers.
4. To remove a bearing cup (race) for replacement from the brake hub, go to [Bearing Cup Inspection and Removal](#) procedure.

Bearing Cup Inspection and Removal

⚠ WARNING

Wear appropriate personal protective equipment (PPE) when performing service or maintenance operations. Always wear eye protection when servicing trailer axles, brakes, hubs, springs and wheels. Not using PPE may result in serious personal injury or death.

Clean brake or idler hub in accordance with [Clean Brake Drum](#) procedure and as follows:

1. Wipe all grease and oil from the hub, using care not to scratch or otherwise mar the bearing race.
2. Apply brake cleaner to hub.
3. Use lint-free cloths to dry the hub and bearing cups.
4. Inspect bearing cups (raceways) for pitting, spalling, corrosion, flat spots, abnormal condition or discoloration.
 - A. If the bearing cup (race) is in good condition, and its mating bearing cone is in reusable condition, the cup can remain installed in the hub for reuse.
 - B. If the bearing cup (race) is in good condition, but the bearing cone is not, the cup **MUST** be replaced.
 - C. If the bearing cup (race) is damaged, the cup **MUST** be replaced.

Replace damaged bearing cups (race) as follows:

1. For either inner or outer bearing cup, use a brass drift punch and hammer to lightly tap around the cup's exposed bearing race edge to push it out.
 - A. Move the drift punch evenly around the bearing cup edge to make sure the cup is pushed out evenly to prevent binding or damage to the bearing cup or hub bore.
2. Set the removed bearing cup aside and place it with its mating bearing cone.

NOTE: Removed bearing cones and cups are not interchangeable.

NOTE: Used bearing cone and cup sets must remain matched and re-installed as a matched set until the set is replaced with a new matching set.

3. After removal of the bearing cups from the hub, re-apply brake cleaner to the hub and the hub bearing cup bores to make sure all surfaces are properly prepared for component reassembly.
 - A. Make sure a drip pan is placed underneath the hub to capture and dispose of the cleaner.

Brake/Idler Hub Installation

Install the brake or idler hub onto the brake drum or spindle as follows:

1. Obtain appropriate hub for installation.
2. Inspect hub for cleanliness.
3. If both bearing cups are installed in the hub bearing bores, go to the Inner Bearing Cone and Grease Seal Installation procedure.
4. If either one of the bearing cups is not installed in the hub, do as follows:
 - A. Place hub on a solid, flat surface with installed bearing cup side of the hub facing down.
 - B. Obtain the appropriate bearing cup for installation. Refer to the Components pages for part numbers.



Bearing cup replacement is a precise procedure. When installed, the bearing cup MUST be fully seated against the retaining shoulder of the hub. If the cup is not seated correctly, damage to the completed hub assembly may occur, voiding warranty.

- C. Bearing cup replacement is a precise procedure. Consult Lippert prior to replacing a bearing cup. The trailer should be taken to a certified service center for this work to be done.
- D. Gently place new bearing cup into hub bearing bore.
- E. Using a brass drift punch, lightly tap around the outer edge of the cup to drive it into the hub bearing bore.
 - I. Continue tapping the drift punch around the circumference of the cup's edge until the cup is fully seated against the hub's bearing bore retaining shoulder.
- F. Wipe the inside of the bearing cup (race) with a clean, lint-free cloth.
 - I. Inspect the bearing cup race to make sure no damage occurred during installation.
5. If no bearing cups are installed in the hub, do as follows:
 - A. Perform step 4 of this procedure.
 - B. Flip hub, exposing the other, open hub bearing bore.
 - C. Perform step 4 of this procedure.
 - D. Make sure both bearing cup races are clean and ready for bearing cone and grease seal installation.
6. After both bearing cups have been installed in the brake or idler hub, go to Inner Bearing Cone and Grease Seal Installation procedure.

Inner Bearing Cone and Grease Seal Installation

Bearing grease should be replaced every 36,000 miles or 12 months, whichever comes first.

1. Make sure all old grease has been removed from wheel hub, bearings and axle spindle.
2. Make sure all mating surfaces for new bearing cone and grease seal are clean.
3. Bearings should be packed by machine, if possible, however packing by hand is a viable alternative.

⚠ WARNING

Do not mix lithium, calcium, sodium or barium complex greases. Mixing of these incompatible compounds can create a corrosive and/or toxic chemical with fumes that can result in a serious health risk if exposed to skin or lungs. When converting from one grease to another, make sure all old grease is removed completely prior to applying new grease.

Hand-pack inner bearing cone as follows:

1. If previously removed inner bearing cone is in reusable condition, place a generous amount of grease into the palm of your hand (Fig. 1).

NOTE: Select an appropriate grease that is temperature-rated for the wheel's application. Reference Recommended Wheel Bearing Grease Specifications and Approved Sources - Bearing Grease charts.

NOTE:

- A. If previously removed inner bearing cone cannot be reused, obtain a new inner bearing cone. Refer to the Components pages for part numbers.
- B. Place a generous amount of grease into the palm of your hand (Fig. 1).

Fig. 1



Approved Sources - Bearing Grease	
Mobil Oil	Mobilgrease HP
Exxon/Standard	Ronex MP
Kendall Refining Co.	Kendall L-427
Ashland Oil Co.	Valvoline Val-plex EP Grease
Pennzoil Prod. Co.	Premium Wheel Bearing Grease 707L

NOTE: Select appropriate grease that is temperature-rated for the wheel's application.

2. Press widest end of bearing into the outer edge of the grease pile, forcing grease into the inner area of the bearing between two adjacent rollers (Fig. 1).
3. Repeat this process while turning bearing from roller to roller until all rollers are coated.
4. Apply a light coat of grease into the bearing cup surface (race).
5. Install new grease-packed bearing cone into the cup.

Recommended Wheel Bearing Grease Specifications	
Thickener Type	Lithium Complex
Dropping Point	230°C (446°F) Minimum
Consistency	NLGI No. 2
Additives	EP, Corrosion and Oxidation Inhibitors
Base Oil	Solvent Refined Petroleum Oil
Base Oil Viscosity	@40°C (104°F) 150cSt (695 SUS) Minimum
Viscosity Index	80 Minimum
Pour Point	-10°C (14°F) Minimum

Lippert recommends replacing the grease seal whenever bearing packing is required. Install a new grease seal into the hub seal bore, to capture the inner bearing cone, as follows:

1. Place the new grease seal into the seal bore.
 - A. Apply a light film of sealant onto the outer rim of the seal.
 - B. Make sure seal is set square to the hub seal bore before pressing the seal all the way in or the seal may become damaged.
2. Use a clean, hardwood block of wood and hammer to drive the seal into the seal bore (Fig. 2).
 - A. Place the wood block evenly across the seal.
 - B. Hold the wood block firmly in place as you begin to tap the seal squarely into the seal bore with the hammer.
 - C. Continue to tap the seal inward until the seal's outer face is flush to the hub's seal bore face.

Fig. 2



Bearing Lubrication - Oil

Recommended Oil Lube for Axle Bearings:

Oil designation : SAE 90, SAE 80W-90, SAE 75W-90

Approved Sources - Bearing Lubrication Oil	
Union Oil Co.	Unocal MP Gear Lube
Exxon Co.	Gear Oil GX 80W-90
Mobil Co.	Mobilube SHC 75W-90
Pennzoil Co.	Gear Plus 80W-90 GL-5
	Gear Plus Super 75W-90

The axle bearings are lubricated with a SAE 80-90W hypoid gear oil. Periodically check oil levels as follows:

1. Make sure trailer has been parked for a few minutes to allow oil to cool.
2. Check and refill brake hub oil to the level indicated on the plastic oil cap.
3. To fill brake hub with oil, remove rubber plug or cap plug from the hub's oil cap.
4. Fill oil through the plastic cap until oil level is complete.
5. Insert rubber plug or cap plug into plastic oil cap.

⚠ CAUTION

Do not over-tighten plastic oil cap. Over-tightening can damage O-ring, resulting in an oil leak.

- A. Tighten oil cap to 25 ft-lbs. Do not over-tighten oil cap or an oil leak may occur.

Refer to the Components pages for part numbers. Refer to Approved Sources - Bearing Lubrication Oil chart for recommended axle bearing lubricants.

Oil Seal

A new two-part oil seal must be installed whenever the brake hub is removed for maintenance. The inside diameter of the two-part seal presses onto the spindle journal, the outside diameter of the seal presses into the brake hub bore.

CAUTION

Never install a removed oil seal. Installing a removed oil seal may damage the seal, resulting in an oil leak during normal component operation.

CAUTION

Make sure the oil seal is properly oriented during part installation. Most oil seals have one side marked "AIR SIDE." This side MUST face outwards and not towards the bearing or component failure will occur.

Make sure when installing a new oil seal the side marked "AIR SIDE" is facing outward, away from the bearing cone.

Periodic Bearing Inspection

A physical bearing inspection should be conducted every 36,000 miles or 12 months, whichever comes first. An inspection of the bearing condition can detect early bearing issues. Upon inspection, bearings should look brand new and can be reassembled and used if in this condition. If discoloration, pitting, corrosion, flat spots or some abnormal condition is observed, the bearing and race should be replaced at the same time. Bearings are available at auto part stores. See Components pages for part numbers.

Spindle Nut Adjustment

The proper method to assemble the spindle nut is as follows:

1. After hub installation onto spindle, install outer bearing.
2. Install spindle washer, if equipped, and thread on spindle nut with slots facing outward.
3. Tighten spindle nut with a pair of slip joint pliers to approx 50 ft-lbs.
4. Back off torque usually 1/4 turn so that you can finger tighten the spindle nut.
5. Finger tighten, drop cotter pin through slot and hole in spindle. If slot in nut does not align with either hole in spindle, back nut off until it does. Never tighten past finger tight. Use cotter pin hole that provides the least amount of end play clearance.
6. Bend legs over end of spindle and be sure legs do not interfere with oil cap upon reassembly.

Disc Brake Option

Disc Brake Pads

Disc brake pads are available through auto part stores. Brake pads are a consumable item so be sure to visually check pads every 36,000 miles or 12 months, whichever comes first. Be sure to also check rotor surfaces visually when you are checking the brake pads. Deep grooves developing on one or both rotor surfaces can indicate a caliper piston, slider bolt or residual pressure problem if this ever occurs. Brake rotors should be turned when disc brake pads are replaced.

Disc Brake Caliper

The proper mounting torque for the disc brake caliper mounting bolts is 40-50 ft-lbs. If these are removed for servicing the brake system, add blue thread locking compound to the threaded area of the bolt at time of reassembly. Also lubricate the inside of caliper bushings that the slider bolts go through. Be sure to only use silicone-based grease. The rubber bushings are not compatible with petroleum-based greases.

Electric Brakes

The basic structure of the Electric Brakes on your trailer will resemble the brakes on your car or tow vehicle, with one major difference; your trailer implements an Electric Actuation system and your tow vehicle utilizes a hydraulic system. Refer to the brake components diagram (Fig. 3), the Wiring Diagram (Fig. 13) and Pigtail and Coupler Wiring Color Codes (Fig. 14). The Electric Braking System operates in the following order of steps:

1. Electric current is supplied to the trailer's braking system when the tow vehicle's brakes are applied.
2. From the tow vehicle's battery, the electricity flows to the brake's electromagnet.
3. When energized, the magnets are attracted to the rotating surface of the drums.
4. This moves the actuating levers in the direction the drums are turning.
5. The actuating cam at the end of the shoe forces the primary shoe out to the drum surface.
6. The force of the primary shoe actuates the secondary shoe to contact the drum.
7. The force applied to the brake drum can be increased by elevating the current flow to the magnet.

How to Use Lippert Electric Brakes Properly

The Lippert Electric Braking System is synchronized with the tow vehicle's brakes. Never attempt to stop the combined load of the tow vehicle and the trailer by using either the tow vehicle brakes or the trailer brakes only. They are designed to work together.

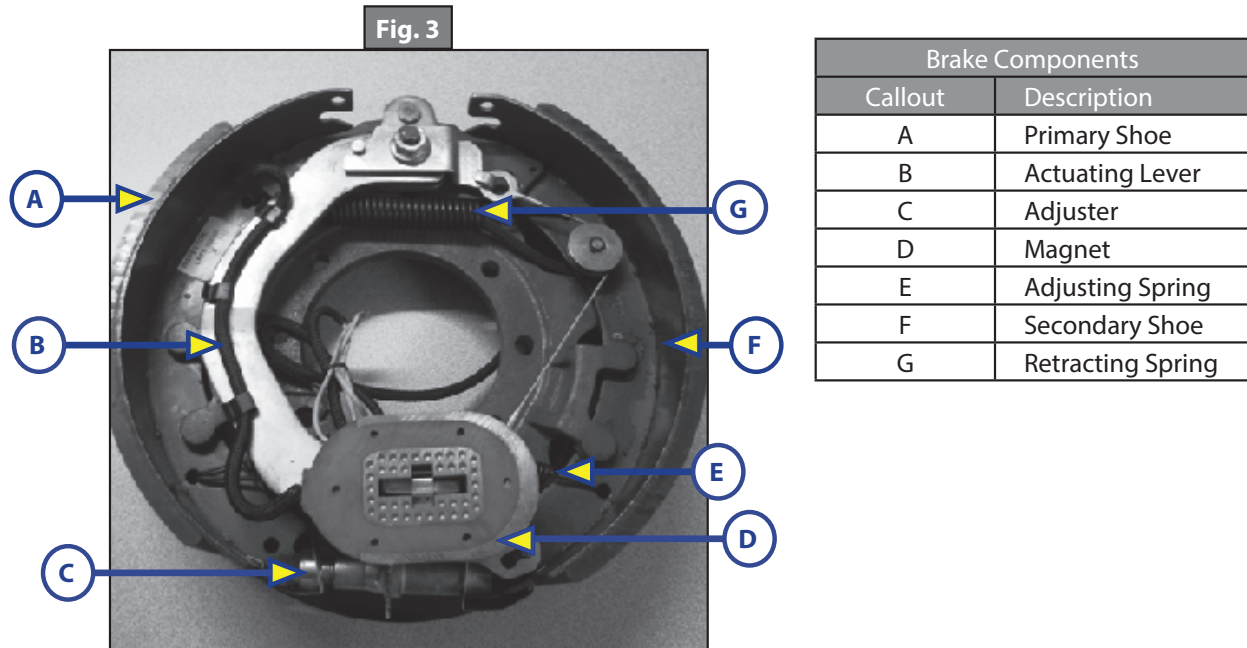

Small manual adjustments may occasionally be necessary to accommodate changing loads and driving conditions. Synchronization of the tow vehicle-to-trailer braking can only be accomplished by road testing. Locking up, excessive grab, or delayed application is quite often due to the lack of synchronization between the tow vehicle and the trailer being towed. High voltage (2V+), Low voltage (2V-) or improperly adjusted brakes are the most common causes of these problems and can easily be corrected.

Prior to any adjustments, your trailer brakes should be burnished-in by applying the brakes 20-30 times with a 20 m.p.h. decrease in speed, e.g. 40 m.p.h. to 20 m.p.h. Allow ample time for brakes to cool between application. This allows the brake shoes and magnets to begin seating to the brake drum.

General Maintenance - Electric Brakes

Brake Adjustment

⚠ WARNING

Prior to testing or adjusting brakes, be sure area is clear of any persons and vehicles. Failure to perform test in a clear area may result in serious injury or death.

⚠ WARNING

Lift the trailer by its frame and never the axle or suspension. Do not go under the trailer unless it is properly supported by jack stands. Unsupported trailers can fall causing serious injury or death.

The Lippert Electric Brakes are offered in a manual and automatic adjusting form. If manual brake adjusting is required, do as follows:

1. Jack up trailer and secure on adequate capacity jack stands.
 - A. Follow trailer manufacturer's recommendations for lifting and supporting the trailer.
 - B. Make sure the wheel and drum rotate freely.
2. Remove the adjusting hole cover from the adjusting slot on the bottom of the brake backing plate.
3. With a screwdriver or standard adjusting tool, rotate the starwheel of the adjuster assembly to expand the brake shoes.
 - A. Adjust the brake shoes out until the pressure of the linings against the drum makes the wheel very difficult to turn.
4. Rotate the starwheel in the opposite direction until the wheel turns freely with a slight lining drag, or approximately 10 click adjustments.

NOTE: A second screwdriver will be needed to push the auto adjusting lever away from the adjuster starwheel so that the starwheel can be rotated backward in the case of a self-adjusting brake.

5. Replace the adjusting hole cover and lower the wheel to the ground.
6. Repeat the above procedure on all brakes.

NOTE: For best results, the brakes should all be set at the same clearance. If the first brake's clearance was adjusted to 10 clicks, then adjust the remaining brake clearances to the same amount.

Lubricate Brakes

Prior to reassembling the brake drum assembly, do as follows:

1. Apply a light film of white grease or an anti-seize compound to:
 - A. The brake anchor pin,
 - B. The actuating arm bushing and pin,
 - C. The areas of the backing plate that are in contact with the brake shoes and magnet lever arm,
 - D. And on the actuating block mounted to the actuating arm.

Clean and Inspect Brakes

In the event the braking system encounters symptoms of improper application or failure, immediate inspection and service **MUST** be implemented. During normal use, servicing the braking system once a year is considered normal. Above normal use will require servicing based on a 3,000-6,000 mile increment schedule. Change worn magnets and shoes as needed to maintain maximum braking capability.

When disassembling the brakes for cleaning, make sure to:

1. Clean the backing plate, magnet arm, magnet and shoes.
2. Make sure all parts removed for cleaning are placed back into the same brake drum assembly.
3. Check for parts that have become loose or worn.
 - A. Service or replace loose or worn parts.

Magnets

Magnets

The Lippert Electric Braking System uses high-quality electromagnets to actuate the brake shoes. These electromagnets provide superior force and friction to safely, and effectively, stop the trailer. Inspect and service the electromagnets annually if the trailer has seen normal use, more often if the trailer is used extensively. Inspect the electromagnets and do as follows:

1. Use a straight edge to check the electromagnet surface for uneven wear (Fig. 4).

NOTE: Figure 4 shows an electromagnet with little or no wear.

- A. Surface of electromagnet should be completely flat.
 - B. If abnormal or uneven wear is indicated by pronounced gaps, replace the electromagnet.
2. If the magnet's coil is exposed in any way, even if normal wear is evident, the magnets should be replaced immediately.
 - A. If the electromagnets are replaced, the drum armature surface should be refaced.
 3. If an electromagnet is replaced on one side of an axle, Lippert recommends replacing the electromagnet on the opposite brake assembly. This will ensure an even braking capacity.

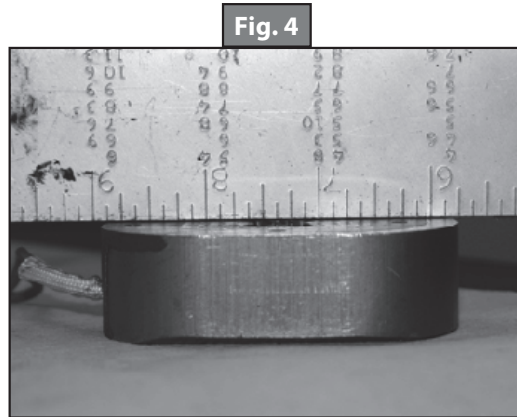

Shoes and Linings

Inspect brake shoes and linings for:

1. Grease or oil.
2. Surface scoring, pitting or gouges.
3. Replace both shoes if lubricant contamination or physical damage is present, even if found on only one shoe.
 - A. Replace both shoes (two) on the brake and on both brakes (four) installed on the same axle. Replace brake parts at the same time. This will ensure an even braking capacity.
4. Measure lining thickness.
 - A. Lining thickness shall not be less than 1/16".
 - I. If lining measures less than 1/16", replace the shoe.
 - II. Repeat step 3.A.
5. Heat cracks are normal and rarely require attention.

After replacing the brake shoes and linings, burnish-in trailer brakes as follows:

1. Apply the brakes 20-30 times over a 20 m.p.h. decreasing speed range.
 - A. For example, brake 20-30 times while decreasing in speed from 40 m.p.h. to 20 m.p.h.
 - B. Make sure ample time is allowed for brakes to cool between application.
 - I. The cooling period allows the brake shoes and magnets to begin seating to the brake drum.

Hub Replacement

To adjust bearings or replace removed hub, follow procedures below:

1. Place hub, bearing, washers and castle nut back on axle spindle in the reverse order from which they were removed. Castle nut should be torqued to 50 ft.-lbs. Hub will rotate during this process.
2. Loosen castle nut to back off the torque.
3. Tighten castle nut finger tight until snug.
4. Insert cotter pin. If cotter pin does not line up with hole, back castle nut up slightly until pin can be inserted (Fig. 5).
5. Bend cotter pin over to lock nut in place. Nut should be free to move with only the cotter pin keeping it in place.

Fig. 5



Axle and Suspension Installation

⚠ CAUTION

Always wear eye protection when servicing the axle, brakes, hubs, springs and wheels. Failure to wear eye protection may result in serious injury.

The single most important portion of axle installation is setting the axle(s) square to the center line of the trailer. Axles mounted out of square will cause the trailer to dog track. Dog-tracking is when the axle is not square to the direction of travel. A skewed axle will cause the trailer to swing out to the left or right until the axle becomes square with the direction of travel. When mounting multiple axles to a trailer, take extra care to get the first axle square to the trailer frame. Proper alignment is most readily achieved by measuring from the center of the trailer hitch to the center of each axle spindle. Once the first axle alignment is established, set the remaining axles parallel with the first. Proper installation allows for correct and safe control, prolonged tread life and will all but eliminate dog-tracking.

Lippert tubular axles are made of high strength steel to prevent metal fatigue and provide the best possible welding conditions. The round tubular axles allow for even and uniform structure.

Suspension Systems

The suspension systems incorporated into Lippert axles are designed to provide the following benefits:

- Attach the axle to the trailer.
- Dampen the effects of road shock.
- Provide stability to the trailer.

All Lippert suspension systems are available in single, tandem and triple axle configurations. For specific or custom applications, please contact the Lippert customer service team.

Double-Eye Leaf Springs

Double-eye leaf springs have eyes at either end of the spring assembly with nylon bushings to assist in preventing wear. U-bolts hold the springs to the axle with a plate (Fig. 6). Refer to Spring Axle Torque Specifications chart for bolt torque requirements.

NOTE: Spring clips are present on the front side of the leaf spring to keep the leaves in line during transport and installation. There is only one clip, located on the front side of the axle so the installer knows front from back. The clip serves no purpose once the axle is mounted, and u-bolts are tightened. They may become loose over time, slip out of position, or possibly come off the leaf spring completely.

Fig. 6 - Double-Eye Leaf Springs

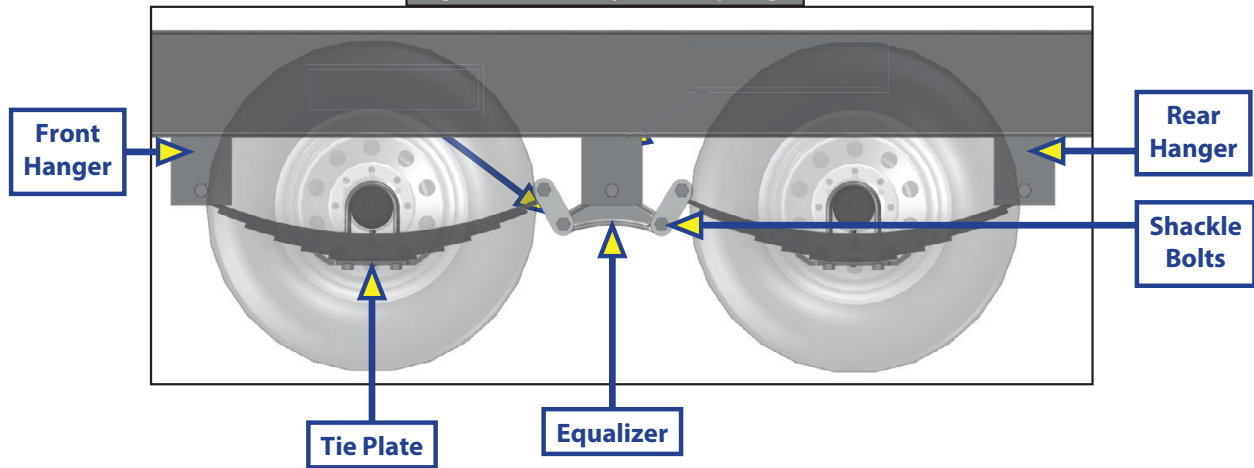

Spring Axle Torque Specifications		
Bolt Type	Axle Capacity	Torque
5/16" U-Bolt Nuts	8K	90 ft-lbs
5/8" U-Bolt Nuts	10K	95 ft-lbs
5/8" U-Bolt Nuts	12K-16K	115 ft-lbs
Spring Eye, Equalizer and Shackle Nuts	8K Double Eye	30-50 ft-lbs
Spring Eye, Equalizer and Shackle Nuts	8K Slipper	Snug nut only
Spring Eye Nut	10K-16K Slipper	200 ft-lbs
Equalizer Nut	10K-16K Slipper	300 ft-lbs
Keeper Nut	10K-16K Slipper	Snug nut only

The articulation of this suspension occurs when the eyes rotate on the wear surfaces provided in eyes of the springs and on the equalizers. This suspension is also available in single and multiple axle configurations. In trailers with two or more axles, the additional movement is maintained by an equalizer. This feature allows for even load handling from axle to axle.

Double-eye suspension systems are available only on 8,000 lb. axles. Tandem and triple axle mounting kits are available for both 33" and 35" axle spacing.

Slipper Leaf Springs—Optional

Slipper springs have a loop eye formed on one end and a reverse radius on the other (Fig. 7). The front eye is secured to either the front hanger or rear of the equalizer with a bolt and nut. The slipper end rides against a wear-block located in either the front of the equalizer or the rear hanger. Refer to Spring Axle Torque Specifications chart for bolt torque requirements.

A keeper bolt or strap is placed under the slipper end to contain the spring when the trailer is lifted off the ground. The 3.5-8K tandem and triple axle attaching kits are available for both 33.5" and 36" axle spacing.

Fig. 7 - Optional Slipper Leaf Springs

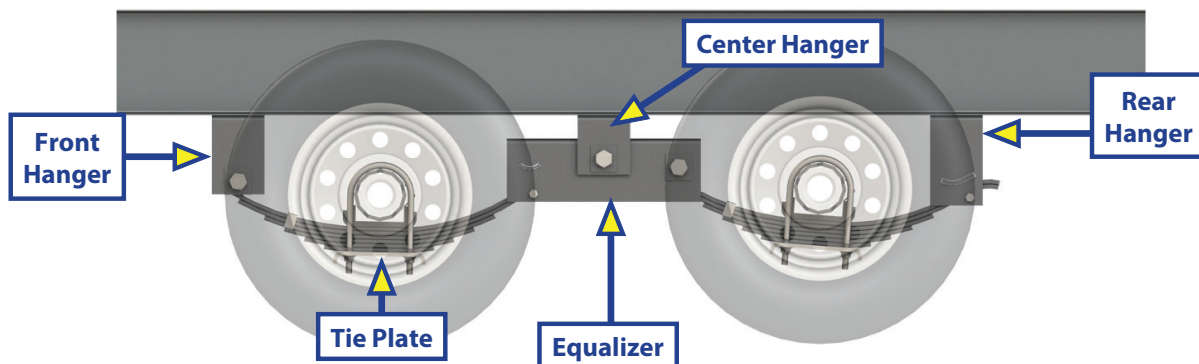

Torsion Suspension System

The Lippert Torsion Suspension system is designed to offer superior qualities over leaf spring technology. Bracketed to the trailer's frame, and housed inside the trailer axle's tube, the spindle is connected to a swing arm, which is connected to a square inner bar surrounded by four rubber cords inside the axle tube. As the swing arm rotates, the rubber absorbs and distributes torque and resistance loads generated by driving conditions. These characteristics provide a measurable benefit over leaf spring suspensions. Torsion axles provide independent wheel end suspension, quieter ride and more vertical wheel travel for a softer ride compared to leaf spring axles.

The Lippert Torsion Suspension system requires very little maintenance. Normal inspection of the entire Lippert Trailer Axle system can be applied to the Torsion Suspension system. See inspection procedures for system components in this manual.

NOTE: For Torsion Suspension System installation, mount axle bracket to frame bracket (Fig. 8) and torque fasteners as specified in the Torsion Axle Torque Specifications chart. Washers **MUST** be placed on both sides of the bracket, including under the nut and under the bolt head (Fig. 8A).

Torsion Axle Torque Specifications		
Axle Size	Bolt Size	Torque Range
8K-10K axle capacities	5/8"	120-150 ft-lbs
12K axle capacity	3/4"	225-250 ft-lbs

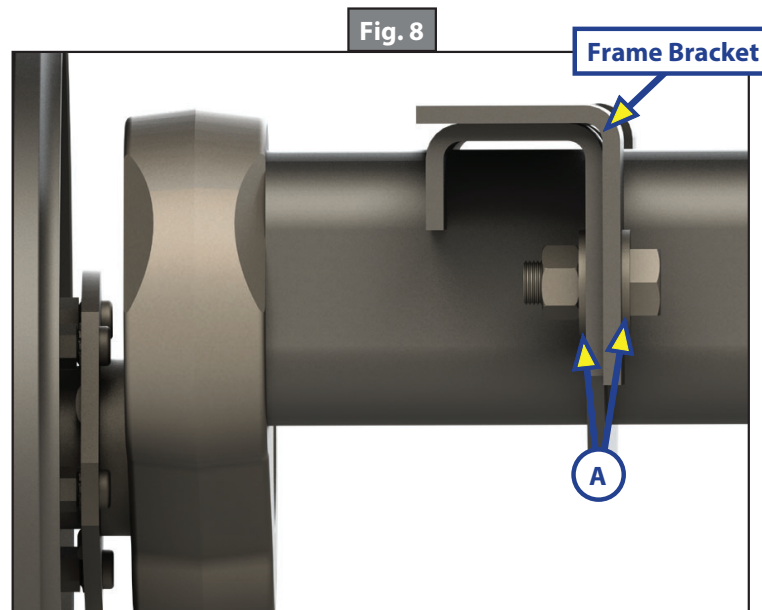

Inspection

Inspect all components of the suspension system annually or every 36,000 miles, whichever comes first. Visually inspect the system for signs of wear, damage or loose fasteners. Replace or tighten loose fasteners, as necessary. Torque fasteners in accordance with specifications in tables Spring Axle Torque Specifications and Torsion Axle Torque Specifications.

⚠ WARNING

Lift the trailer by its frame and never the axle or suspension. Do not go under the trailer unless it is properly supported by jack stands. Unsupported trailers can fall causing serious personal injury or death.

⚠ WARNING

Lift the trailer by its frame and never the axle or suspension. Unsupported trailers can fall causing damage to the frame, axles, suspension system and the trailer. Improper trailer support will void warranty coverage for incurred damages.

⚠ WARNING

Wear eye protection when servicing axles, brakes, hubs, springs and wheels. Failure to wear eye protection may result in serious personal injury.

Refer to the Components pages and the appropriate Service Kit Part # (illustrated parts list) for part descriptions and numbers of replacement components. Replace worn spring eye bushings and sagging or broken springs as follows:

1. Support the trailer with the wheels just off the ground. Follow the trailer manufacturer's recommendations for lifting and supporting the trailer.
2. After the trailer is properly supported, place a suitable block under the axle tube near the area to be repaired.

NOTE: The block acts as a support for the weight of the axle only, allowing suspended system components to be serviced or replaced freely. Multiple axle trailers **MUST** have the weight of each axle properly supported before disassembly of any suspension system component.

3. Disassemble the U-bolts, nuts and tie plates.
4. Remove the spring eye bolts and the spring.
5. If the spring eye bushings are to be replaced, press out the old bushing by hand or use a punch to tap it out.
6. Obtain a new free-floating nylon bushing.

NOTE: Free-floating nylon bushings do not require lubrication.

7. Press the new bushing into the spring eye by hand or gently tap it into place with a bounceless rubber or plastic mallet.
8. Install remaining repaired or new suspension system components in reverse order of their original disassembly sequence.

Equalizer Replacement

Refer to the Components pages and the appropriate Service Kit Part # (illustrated parts list) for part descriptions and numbers of replacement components. Replace equalizer or equalizer bushings as follows:

1. Support the trailer with the wheels just off the ground. Follow the trailer manufacturer's recommendations for lifting and supporting the trailer.
2. After the trailer is properly supported, place a suitable block under both axle tubes.
3. Remove the spring eyebolt, keeper bolt, and equalizer bolt from the equalizer.
4. Press the old nylon bushing out of the equalizer.
5. Install removed equalizer parts in reverse order of their original disassembly sequence.

Suspension Replacement

Install replacement springs and equalizers as follows:

1. Make sure springs are on straight.
 - A. Align spring eyes to front hanger.
 - B. Insert spring eye bolts and nuts, but do not torque fasteners at this point.
2. Assemble springs to equalizer.
3. Level the equalizer to the frame.
 - A. Torque equalizer nuts and spring eye nuts to 30-50 ft.-lbs.

Wheels

Wheel Selection

⚠ WARNING

Air pressure on a weakened or cracked rim can create an unsafe, explosive condition resulting in serious personal injury or death. Do not attempt to modify or repair a wheel. Replace damaged or weakened wheel and rim with new.

⚠ WARNING

Use manufacturer's suggested rim contours only. Failure to use recommended rim contours may result in dramatic separation between tire and wheel, resulting in possible serious personal injury or death.

Trailer wheels, tires and axles **MUST** be properly matched when specifying or replacing trailer wheels. Make sure the following critical wheel replacement characteristics are observed:

1. Bolt Circle.
 - A. Wheels have varying bolt circle patterns, some close enough to allow installation of mismatched wheel bolt patterns to axle hub bolt patterns.
2. Capacity.
 - A. Wheel load capacity **MUST** match tire and trailer maximum load ratings.
3. Offset.
 - A. The relationship of the tire's centerline to the axle's hub face **MUST** match across replacement parts.
 - B. Failure to match offset reduces axle carrying capacity.
4. Rim Contour.
 - A. Replacement wheels **MUST** directly match the mating rim contour.

Torque Requirements

It is extremely important to maintain proper wheel mounting torque limits on your trailer axle. Use of torque wrenches will ensure proper torque limits are applied to wheel mounting lug nuts. Use no other method to torque wheel lug nuts.

Make sure wheel fasteners match the cone angle of the wheel (usually 60° or 90°) being serviced. Attach new wheel to the axle hub as follows:

1. Start all bolts or nuts by hand to prevent cross-threading.
2. Continue to hand-tighten wheel lug nuts in the sequential pattern shown in Figure 9.
3. After wheel lug nuts are fully hand-tightened, torque nuts in stages in the sequential pattern shown in Figure 9.
 - A. Torque wheel lug nuts to the torque values listed in the Wheel Torque Requirement Chart.

Fig. 9



Wheel Torque Requirement Chart				
Wheel Size	Stud Size	Torque Sequence		
		1st Stage	2nd Stage	3rd Stage
16" Dual and 17.5" Cone Nut	5/8"	50-60 ft-lbs	100-120 ft-lbs	190-210 ft-lbs
16" Dual and 17.5" One-Piece Flange Nut	5/8"	50-60 ft-lbs	150-200 ft-lbs	275-325 ft-lbs
16" Dual and 17.5" Swivel Flange Nut	5/8"	50-60 ft-lbs	90-100 ft-lbs	150-175 ft-lbs
17.5" Dual Flange Nut	M22	50-100 ft-lbs	250-300 ft-lbs	450-500 ft-lbs

⚠ WARNING

Proper and accurate torque MUST be maintained to prevent wheels from loosening, studs from cracking and/or breaking or other possible hazardous breakage resulting in serious injury or death.

4. Wheel lug nuts should be torqued before first road use and after each wheel removal.
 - A. Check and re-torque wheel lug nuts after 10, 25 and 50 miles. A periodic check during regular service is recommended.







Tires

Prior to mounting tires onto wheels, do as follows:

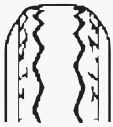
1. Make sure rim size and contour are approved by the Tire and Rim Association Yearbook or the tire manufacturer's catalog.
2. Verify tire load rating.
 - A. If the load is not evenly distributed across all tires, use the tire rated for the heaviest wheel position.
3. Consult the Rubber Manufacturers Association or the tire manufacturer's guidelines for wheel mounting procedures.

Tire pressure is very important to promoting tire life and performance. Tire pressure should always be in accordance with the manufacturer's recommended pressure rating for any given load. Check tire pressure as follows:

1. Always check tire pressure cold before operation.
2. Do not bleed air from tires when they are hot.

Tire Tread Wear Pattern Chart		
What Is Happening?	Why?	What Should Be Done?
Center Wear 	Over-inflation	Adjust pressure to particular load per tire catalog.
Edge Wear 	Under-inflation	Adjust pressure to particular load per tire catalog.
Side Wear 	Loss of camber or overloading	Make sure load does not exceed axle rating. Call Lippert Service & Warranty to advise.
Toe Wear 	Incorrect Toe-in	Call Lippert Service & Warranty to advise.
Cupping 	Out-of-balance	Check bearing adjustment and balance tires.
Flat Spots 	Wheel lockup and tire skidding	Avoid sudden stop if possible and adjust brakes.

3. Check inflation pressure weekly during use to ensure maximum tire and tread life.
4. Inspect for tire tread wear patterns that may indicate serious wheel alignment or excessive load limit issues. Refer to the Tire Tread Wear Pattern Chart.

NOTE: Tire wear should be checked frequently. Once a tire wear pattern is established, stopping becomes difficult, even when the underlying cause is corrected.

Introduction to Troubleshooting

The following section is a guideline for ensuring operation of your braking system. The safety of you, those traveling with you and those sharing the road is paramount and it starts with the ability to safely stop the tow vehicle and the towed vehicle.

Troubleshooting

Most brake malfunctions can be corrected by utilizing the Troubleshooting Chart. Mechanical failure is the most common form of malfunction, however, if the brake system fails and it's not mechanical, it is usually electrical. A Voltmeter and Ammeter are essential tools to diagnosing these problems.

Mechanical problems are mostly self-evident; something is bent or broken. Consult the Troubleshooting Chart to determine the probable cause and corrective actions for a variety of issues with the braking system.

Remember to use only Lippert replacement parts on these systems. Consult the Limited Warranty or call our Service Department for any other related issues.

Troubleshooting Chart

NOTE: If all trailer lights and brakes do not work, check your wiring plug connection (Wiring Diagram, Fig. 13). Make sure the ball is making solid contact with the coupler (that is how a trailer is grounded). Too much grease or not using dielectric grease on the ball and coupler can cause this to happen.

Measuring Voltage

The Braking System voltage is measured at the two lead wires of the magnet on any brake. Use the pin probes inserted through the insulation of the lead wires. To ensure that the battery is indicating a full charge, the towing vehicle engine should be running with the trailer coupler connected when checking the voltage.

Voltage in the system should begin at 0 volts and, as the brake pedal of the tow vehicle is applied, voltage will gradually increase to about 12 volts. If the system does not indicate at least 12 volts, problems may occur in the wiring of the system, the battery or alternator of the tow vehicle.

When the brakes are applied, a gradual increase in voltage is preferable to a quick increase to 12 volts. A gradual increase in voltage ensures smooth and firm trailer braking. A quick increase in voltage will cause the braking system to feel like the trailer is grabbing too quickly.

Taking a voltage reading is usually done with probes inserted into the wire connector (Fig. 10).

Measuring Amperage

Braking System amperage is the amount of current flowing through the system when all magnets have been energized. Amperage will change proportionately with voltage. To ensure the battery is fully charged, the tow vehicle engine should be running with the trailer coupler connected when checking the voltage.

If a resistor is used in the brake system, it **MUST** be set at zero or bypassed completely to obtain the maximum amperage reading. Individual amperage draw can be measured by inserting the ammeter in the line at the magnet you want to check. Disconnect one of the magnet lead wire connectors and attach the ammeter between the two wires. Consult Amperage Chart for normal amp readings.

Fig. 10

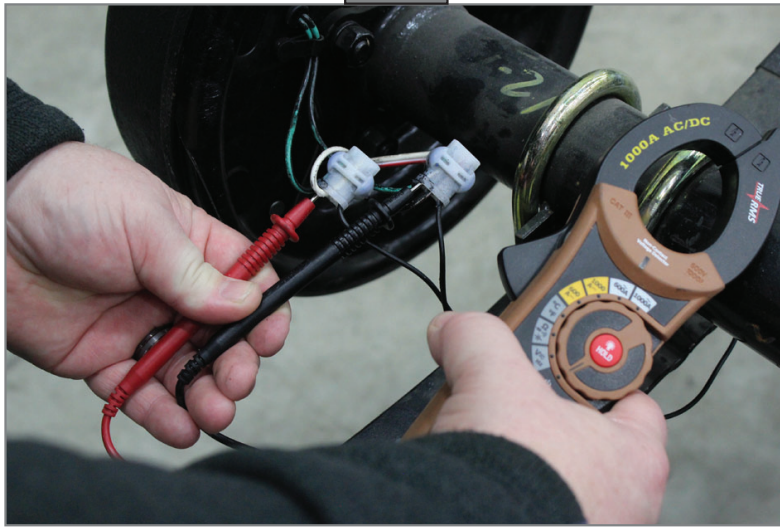

Fig. 11

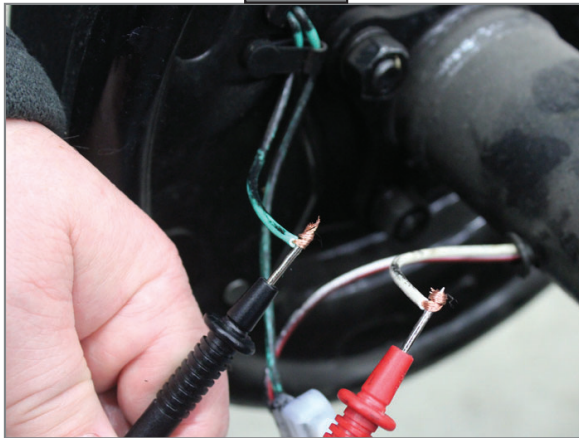
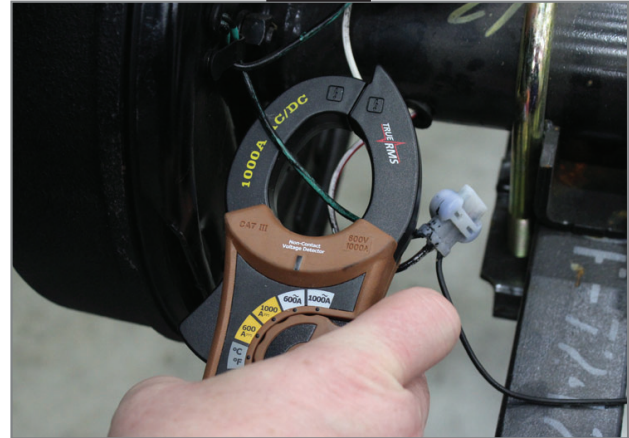

Fig. 12



Make sure that the wires are properly reconnected and sealed after testing is completed. Testing for amperage can be done with probes (Fig. 11) or alligator clips on the leads or an amp clamp (Fig. 12).

Amperage Chart

Amperage Chart			
Amps/Magnet	Two Brakes	Four Brakes	Six Brakes
3.0	6.0	12.0	18.0

Low or no voltage are the most common problems with the Braking System. Amperage at the brakes is also a relatively common issue. Common causes of these conditions are:

1. Low quality electrical connections.
2. Open circuits.
3. Insufficient wire gauge. (Reference Trailer Wire Gauge chart.)
4. Broken wires.
5. Blown fuses (fusing of brakes is not recommended).
6. Short circuits (indicated by high amperage).

Trailer Wire Gauge Chart		
Wire Gauge and Type	Number of Axles	Length of Run
16 Ga Stranded Copper	1	N/A
14 Ga Stranded Copper	2	Under 30ft. (9.1m) from hitch to center of axles
12 Ga Stranded Copper	2 or 3	Over 30ft. (9.1m) from hitch to center of axles

Possible causes of shorts are:

1. Shorted magnet coils.
2. Bare wires contacting a grounded object.

Finding the cause of a short circuit in the system is done by isolating one section at a time. If the high amperage reading drops to zero by unplugging the trailer, then the short is in the trailer. If the amperage reading remains high with all the brake magnets disconnected, the short is in the trailer wiring.

All electrical troubleshooting procedures should start at the controller. Most complaints regarding brake harshness or malfunction are traceable to improperly adjusted or nonfunctional controllers. See your controller manufacturer's data for proper adjustment and testing procedures. For best results, all the connection points in the brake wiring should be sealed to prevent corrosion. Loose or corroded connectors will cause an increase in resistance which reduces the voltage available for the brake magnets.

Troubleshooting Chart		
What Is Happening?	Why?	What Should Be Done?
No brakes	Open circuits	Find and correct
	Short circuits	Test and correct
	Severe under-adjustment	Adjust brakes
Weak brakes	Grease or oil on magnets or linings	Clean or replace
	Corroded connections	Clean and correct cause of corrosion
	Worn linings or magnets	Replace
	Scored or grooved brake drums	Machine or replace
	Improper synchronization	Correct
	Under-adjustment	Adjust brakes
	Glazed Linings	Re-burnish or replace
Locking brakes	Under-adjustment	Adjust brakes
	Improper synchronization	
	Loose, bent or broken brake components	Test and correct
	Out-of-round brake drums	Machine or replace
	Insufficient wheel load	Adjust system resistor and synchronize
Intermittent brakes	Broken wires	Test and correct
	Loose connections	Repair or replace
	Faulty ground	Find and repair
Brakes pull to one side	Wrong magnet lead wire color	Adjust
	Incorrect adjustment	Correct
	Grease or oil on linings or magnets	Clean or replace
	Broken wires	Find and repair
	Bad connections	Find and repair
Harsh brakes	Under-adjustment	Adjust brakes
	Improper synchronization	Correct
Noisy brakes	Under-adjustment	Adjust brakes
	Lack of lubrication	Lubricate
	Broken component	Replace component
	Incorrect brake components	Correct
Surging brakes	Grease or oil on linings or magnets	Clean or replace
	Out-of-round or cracked brake drums	Machine or replace
Dragging brakes	Over-adjustment	Readjust
	Out-of-round brake drums	Machine or replace
	Incorrect brake components	Replace
	Loose, bent or broken brake components	Replace
	Faulty breakaway switch	Repair or replace
	Loose wheel bearing adjustment	Adjust
	Bent spindle	Replace Axle

Maintenance Schedule

Item	Function Required	3,000 Miles	12 Months / 36,000 Miles (Whichever comes first)
Brakes	Test that they are operational.	At Every Use	
Oil Level	Check oil level in hubs, if equipped.	At Every Use	
Brake Adjustment	Adjust to proper operating clearance. Not required for self-adjusting brakes.	◆	
Brake Magnets	Inspect for wear and current draw.		◆
Brake Linings and Pads	Inspect for wear or contamination.		◆
Hub/Drum and Rotors	Inspect for abnormal wear or scoring.		◆
Wheel Bearing	Inspect for corrosion or wear. Clean and repack.		◆
Seals	Inspect for leakage. Replace if removed.		◆
Springs	Inspect for wear, loss of arch.		◆
Suspension Parts	Inspect for bending, loose fasteners, wear.		◆
U-bolts	Tighten to specified torque values		◆

Wiring Diagram

Fig. 13

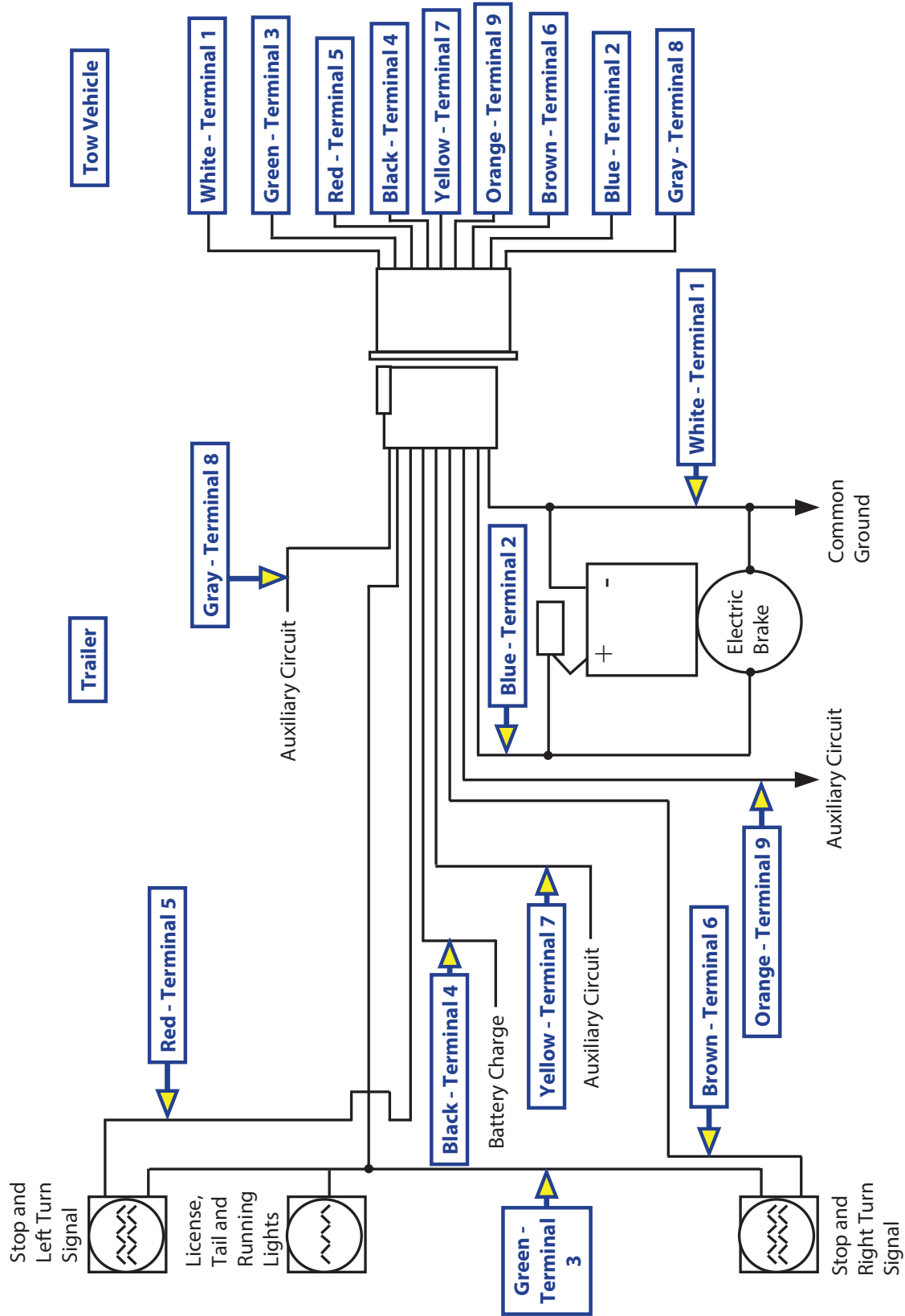
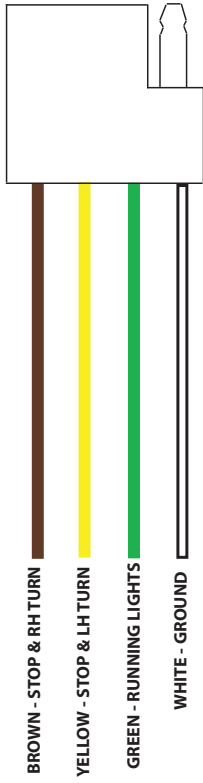
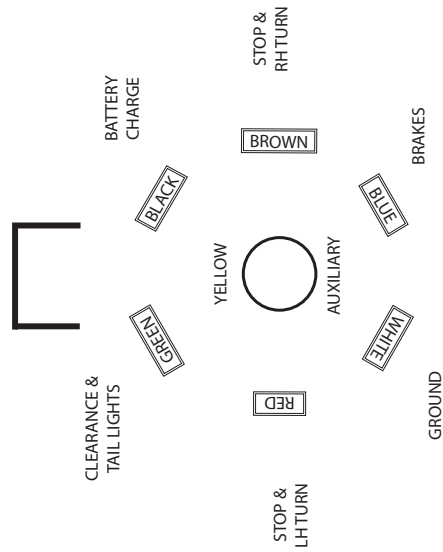

Fig. 14



TRAILER LIGHTS PIGTAIL - DOES NOT OPERATE BRAKES

7-PIN COUPLER



9-PIN COUPLER

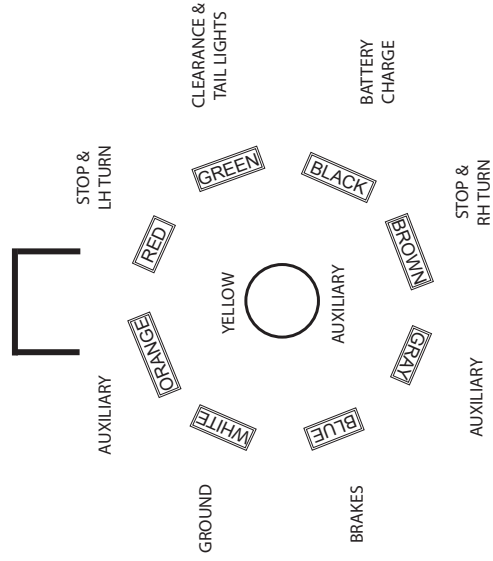

TRAILER BRAKE AND LIGHT COUPLER - OPERATES BRAKES

Storage

Storage Preparation

If your trailer is to be stored for an extended period of time, the trailer will need to be prepared prior to going into storage. Follow these guidelines to set up your trailer for storage:

1. If the trailer has an emergency breakaway battery, remove it and store it inside, out of the weather. Charge the battery at least every 90 days.
2. Jack up the trailer and place jack stands under the trailer frame so that the weight will be off the tires. Follow trailer manufacturer's guidelines to lift and support the trailer.
3. Lubricate mechanical moving parts such as the hitch, and suspension parts, that are exposed to the weather.
4. In the case of boat trailer axles that are subject to repeated immersion, remove brake drums; clean, dry and re-lubricate moving brake components; inspect bearings - clean and re-lubricate.

⚠️WARNING

Lift the trailer by its frame and never the axle or suspension. Do not go under the trailer unless it is properly supported by jack stands. Unsupported trailers can fall causing death or serious injury.

Extended Storage Inspection Procedures

Trailer should remain on jack stands during this procedure:

1. Remove all wheels and hubs or brake drums. Reinstall drum to same spindle and brake from which it was removed.
2. Inspect suspension for wear.
3. Check tightness of hanger bolt, shackle bolt, and U-bolt nuts of the suspension for correct torque.
4. Check brake linings, brake drums and armature faces for excessive wear, scoring, damage or corrosion.
5. Check brake magnets with an ohmmeter. The magnets should check 3.2 ohms. If shorted or worn excessively, they must be replaced.
6. Lubricate all brake moving parts using a high temperature brake lubricant.
7. Remove any rust from braking surface and armature surface of drums with fine emery paper or crocus cloth. Be sure to protect bearings from contaminating dust.
8. Inspect oil or grease seals for wear or nicks. Replace if necessary. Using the [Trip Preparation Checklist](#) before starting a trip with your trailer is highly recommended. Allow plenty of time prior to any trip for any service or repairs that may need to be done before using the trailer.
9. Lubricate hub bearings.
10. Reinstall hubs and adjust bearings.
11. Mount and tighten wheels.

NOTE: Avoid getting any grease or oil on brake linings and pads or magnet surfaces.

Trip Preparation Checklist

The following checklist offers several guidelines to prolonging the quality of your running gear and will provide trustworthy and safe trailering for years to come.

Using the following checklist before starting a trip with your trailer is highly recommended. Allow plenty of time prior to any trip for any service or repairs that may need to be done before using the trailer.

1. Maintenance schedule should be current.
2. Inspect hitch for corrosion, lubrication and wear.
3. Inspect safety chains for rust and wear. Engage chains and breakaway switch actuating chain securely. Breakaway battery should be fully charged.
4. Electronic coupler must be secure. Run check on all lights and brake engagement and synchronization. Refer to Figures 13 and 14.
5. Load trailer with 10% of total weight on the hitch end of trailer. Smaller trailers' front end load should be increased to 15%.
6. Do not overload. Consult your trailers i.d. plate for gross vehicle weight restrictions.
7. Tires should be inflated to manufacturer's specifications. Inspect tires for any damage or wear.
8. Inspect lug nuts/bolts. All should be torqued to specifications. Refer to Wheel Torque Requirement Chart for torque limits.
9. Check torque of hanger bolt, shackle bolt, and U-bolt nuts on suspension.
10. Check that your trailer is towing level. Adjust hitch height if necessary to level trailer.

Limited Warranty

LIPPERT COMPONENTS® AXLE LIMITED WARRANTY (NORTH AMERICAN OEM SALES)

This Axle Limited Warranty ("Warranty") outlines applicable coverage and claim procedures for Products incorporated into units or trailers retail sold after January 1, 2017, as defined herein, sold by Lippert Components, Inc. or its subsidiaries or affiliates (the direct seller being the only warrantor referenced herein as "Warrantor", "we", "us" or "our").

Coverage. Subject to these terms, we warrant ONLY to you, the original equipment manufacturer ("OEM", "you" or "your"), that the axles and suspension systems that we manufacture, distribute and/or sell to you that are not already covered by a separate written warranty from another manufacturer (the "Product(s)") will be free from defects in materials and workmanship at the time of sale. We will honor this Warranty for the applicable period from the date of retail purchase, and cover only Products sold and used in the United States and Canada. The Warranty period shall be as follows:

Limited 1 Year Warranty – grease and oil seals for all Products.

Limited 6 Year Warranty – spring axles and suspension systems.

Limited 11 Year Warranty – torsion axles.

Service. For Products having a covered defect within the Warranty period, we will, in our sole and absolute discretion, repair or replace the Product with a new or refurbished component, or provide a pro rata refund of that portion of the Product. Labor will be allowed if a designated flat rate time is outlined by us and will be limited to the published flat rate amount. There is no other warranty.

Notice. No remedy will be required or offered unless we receive written notice of a claimed defect. You must make any claim of defect, including without limitation under this Warranty, in writing, with full particulars, promptly after the defect was or reasonably should have been discovered, and in any event no later than sixty (60) days of its discovery. In the event of any accident, injury to person, damage to property, or other loss involving a Product, you must notify us in writing within thirty (30) days of the incident or within ten (10) days of notification to you, whichever is earlier. In the event of any survey, test, or inspection to be conducted on a Product, you must notify us in writing immediately so that we, at our sole election, may participate in that activity or conduct our own survey, test, or inspection in advance. Your written notice must describe the defect, provide the customer's name and address, state the location of the Product, and provide us full particulars (see below). As a condition of coverage, we must be provided access to the original Product for inspection, testing, or other work at our discretion. The Product must remain unmodified. We will not consider any claims for Products (or any components thereof) that are not in their original form. Failure to give us proper or timely notice of a claimed defect, or failure to return the defective Product, or performing any modification, self-help, or alteration of the Product, without our prior written approval, will constitute an absolute waiver and release of all your claims and rights under this Warranty.

Transferability. THIS WARRANTY IS NOT ASSIGNABLE OR TRANSFERABLE. THIS WARRANTY EXTENDS ONLY TO YOU, THE ORIGINAL OEM PURCHASER PURCHASING A PRODUCT DIRECTLY FROM WARRANTOR'S FACILITIES, AND WILL NOT BE CONSTRUED TO EXTEND TO ANY THIRD-PARTY, INCLUDING WITHOUT LIMITATION THE ULTIMATE RETAIL PURCHASER OR CONSUMER OF AN END PRODUCT. YOU MAY NOT REPRESENT TO ANYONE, INCLUDING YOUR CUSTOMER OR AN END CONSUMER THAT THIS WARRANTY EXTENDS TO THEM.

Limitations. THERE IS NO WARRANTY OF MERCHANTABILITY OR FITNESS FOR A PARTICULAR PURPOSE, TO THE FULL EXTENT DISCLAIMER IS PERMITTED BY LAW. IN ANY EVENT, ANY IMPLIED WARRANTY THAT MAY ARISE BY LAW IS LIMITED IN DURATION TO THE TERM HEREIN AND TO THE COVERED PRODUCTS. THE REPAIR, REPLACEMENT, OR REFUND PROVIDED HEREIN IS EXCLUSIVE AND IN LIEU OF ALL OTHER REMEDIES. EXCEPT AS PROVIDED IN THIS WARRANTY, ALL PRODUCTS ARE BEING SOLD "AS IS" AND "WITH ALL FAULTS." ALL RISKS AS TO PRODUCT QUALITY OR PERFORMANCE NOT CONTEMPLATED BY THIS WARRANTY WILL BE BORNE EXCLUSIVELY BY YOU, THE PURCHASER. IF A PRODUCT PROVES DEFECTIVE AFTER ITS PURCHASE, YOU, NOT US, ASSUME THE ENTIRE COST OF ALL NECESSARY SERVICING OR REPAIR THAT IS NOT COVERED UNDER THIS WARRANTY. IN NO EVENT WILL WE BE LIABLE FOR COSTS OF REMOVAL OR REINSTALLATION OF THE PRODUCTS, OR ANY EXPENSE RELATED TO REINSTALLATION. WE WILL HAVE NO LIABILITY TO ANYONE FOR CONSEQUENTIAL, SPECIAL, INCIDENTAL, INDIRECT, EXEMPLARY, OR PUNITIVE DAMAGES OF ANY KIND WHATSOEVER, INCLUDING WITHOUT LIMITATION PROPERTY DAMAGE, LOST PROFITS, LABOR COSTS, OR ANY OTHER PECUNIARY DAMAGE, WHETHER DUE TO ANY DEFECT IN THE PRODUCTS, BREACH, DELAY, NON-DELIVERY, NON-PERFORMANCE, RECALL, OR ANY OTHER REASON. ALL CLAIMS FOR NEGLIGENCE AND FOR FAILURE OF ESSENTIAL PURPOSE ARE EXPRESSLY WAIVED AND RELEASED. UNDER NO CIRCUMSTANCES WILL OUR LIABILITY FOR ANY DEFECT IN THE GOODS, WHETHER BASED ON CONTRACT, TORT, WARRANTY, OR ANY OTHER THEORY, EXCEED THE PURCHASE PRICE OF THE PRODUCTS. THERE ARE NO THIRD-PARTY BENEFICIARIES TO THE WARRANTY'S TERMS. YOU WAIVE ANY RIGHT TO A JURY TRIAL AND CLASS ACTION RELATING TO THIS WARRANTY, AND MAY NOT JOIN OR CONSOLIDATE CLAIMS AS A REPRESENTATIVE OF A CLASS ACTION OR IN A PRIVATE ATTORNEY GENERAL CAPACITY. THESE PROVISIONS PROVIDE SPECIFIC LEGAL RIGHTS AND LIMITATIONS. SOME MAY NOT APPLY BASED ON STATE OR FEDERAL LAW, AND OTHER LEGAL RIGHTS MAY EXIST.

Exclusions. This Warranty only covers the Products. Due to the intended use of our Products, any and all items and components not sold by us but attached to, incorporated into, or using our Products carry NO WARRANTY WHATSOEVER from us regardless of circumstance. We will not be liable for any defects, whether due to workmanship, materials or any other reason whatsoever, for those items and components not sold by us. This Warranty also does not cover customer instruction, installation and labor (except as provided herein), parts supplied by others, abuse, misuse, neglect, improper installation or improper repair by anyone other than us, improper usage, overloading, accidents, unreasonable use, improper loading, improper operation, improper repair, improper

maintenance, normal wear and tear, normal wear components (including bolts, nuts, shackles, and riding enhancement products) color fade, mold, mildew, corrosion, rust formation, modifications, or attempted repair by anyone other than a qualified repair facility. This Warranty does not cover chemical damage caused by acids, fuel, oil, or other chemicals. Use of our Products in or as part of a unit in a rental fleet, or for a commercial or industrial purpose, voids your rights under this Warranty. The Warranty also does not extend to and does not cover defects caused by the following:

The connecting of brake wiring to the trailer wiring or trailer wiring to the towing vehicle wiring.

The attachment of the axles and running gear to the chassis/frame.

Any and all damage caused by or related to any alteration of the axle or running gear including welding supplemental brackets to the axle.

Improper alignment.

Unreasonable use, including failure to perform reasonable and necessary maintenance in accordance with our operations and service manuals with proof of such maintenance (including required maintenance after prolonged storage.)

Use of an axle on a unit/trailer other than the unit/trailer to which it was originally mounted.

Improper torque values and torquing of wheel nuts not in accordance with our operations manual.

Indemnity. You agree to indemnify and hold us, as well as our officers, agents, employees, and representatives, harmless from and against all claims, causes of action, liabilities, losses, damages, judgments, and proceedings, whether based in contract, quasi-contract, subrogation, tort, strict liability, or any other legal or equitable theory, including without limitation all expenses, costs, damages or injury to person or property, and attorney fees incident thereto, arising from or relating to your handling, storage, transportation, possession, processing, fabrication, resale, or any other activity involving the Products after delivery, or relating to any extension or attempt to extend, assign, transfer, or pass this Warranty through to anyone else. At our request, and subject to our sole discretion to choose our own counsel, you will also defend us from any such claims, causes of action, or proceedings.

Statute of Limitations. Any action, lawsuit or other proceeding, under this Warranty or otherwise, related to the Product must be commenced within one (1) year after the earlier of (a) the expiration of the applicable Warranty coverage period, (b) our alleged failure to repair the defect at issue; or (c) the date on which your claim accrues under applicable law. Unless prohibited by law, the performance of repairs will not prevent the limitations period from expiring, nor will any tolling or estoppel doctrine apply. This Warranty does not extend to future performance.

Applicable Law & Venue. This Warranty will be governed by and construed in accordance with the laws of the State of Indiana without regard to principles of conflicts of law. Any disagreement, dispute, controversy, or claim arising out of or relating to this Warranty must be submitted to binding arbitration in accordance with the Rules of the American Arbitration Association. Judgment upon the award may be entered in any court having jurisdiction thereof. In the event you bring any claim against us in violation of this Warranty or for claims waived or released under this Warranty, you agree to pay our attorney and paralegal fees and costs to defend such suit.

Modifications. We will not be liable for commitments, promises, or agreements made by any employee, agent, or dealer that is not in accordance with this Warranty. The current warranties and terms outlined on the Warrantor's website (www.lci1.com) applicable on the date of purchase take precedence over any other warranties, whether oral or written. We reserve the right to alter our warranties from time to time, as the laws and our business needs and industry change. Any conditions or exceptions that may be stated in any communication or document to us from any entity or individual, including but not limited to the retail purchaser or consumer, shall be of no effect unless specifically agreed to in writing and hand-signed by our authorized representative.

Miscellaneous. Any legally or otherwise invalid provision hereof will be considered severable, with all remaining provisions enforceable. We have all rights and remedies given to sellers by applicable law, and our rights and remedies are cumulative and may be exercised from time to time. No waiver by us of any provision of this Warranty will be effective unless in writing, nor will it operate as a novation or waiver of any other provision or affect our right to exercise thereafter any right or remedy. We will not lose any right because we have not exercised that right in the past.

For questions and claims, contact Lippert Components, Inc., Attn. Warranty Dept., 1902 West Sample Street, South Bend, Indiana 46619. The telephone number to obtain the name and address of the service and repair facility nearest you is 1-574-537-8900. You may also email your claim to customerservice@lci1.com. To process your claim, we will need the following information: vehicle identification number (VIN), date of manufacture, date of purchase, the make and full model number, pictures of alleged defect, and description of alleged defect. Please include this information with any correspondence and have this information available when you call.



The contents of this manual are proprietary and copyright protected by Lippert. Lippert prohibits the copying or dissemination of portions of this manual unless prior written consent from an authorized Lippert representative has been provided. Any unauthorized use shall void any applicable warranty. The information contained in this manual is subject to change without notice and at the sole discretion of Lippert. Revised editions are available for free download from lippert.com.

Please recycle all obsolete materials.

For all concerns or questions, please contact Lippert
Ph: 432-LIPPERT (432-547-7378) | Web: lippert.com | Email: customerservice@lci1.com

AXLES AND SUSPENSION

Purpose

To maintain and extend the product life of the Lippert® trailer axle product line.

Introduction

A QR code on the axle serial number label will also supply access to this online support documentation as well as provide information for OEMs. If using an Android camera phone to scan the label's QR code, it will provide a link to the website in addition to information on serial number, load rating, item number and description, customer and manufacturer purchase information and manufacture date. If using an iPhone, scanning the QR code with its camera will supply only the Lippert website link. A QR code reader app is needed on an iPhone to access the OEM information.



Safety

⚠ WARNING

Failure to follow the instructions provided in this manual may result in death, serious personal injury, severe product or property damage, or voiding of the component warranty.

⚠ WARNING

Prior to testing or adjusting brakes, make sure area is clear of any persons and vehicles. Failure to perform test may result in serious personal injury, or severe product or property damage.

⚠ WARNING

Lift the trailer by its frame and never the axle or suspension. Do not go under the trailer unless it is properly supported by jack stands. Unsupported trailers can fall causing death, serious personal injury, or severe product or property damage.

⚠ CAUTION

Always wear eye protection when servicing the axle, brakes, hubs, springs and wheels. Failure to wear eye protection may result in injury.

⚠ CAUTION

Moving parts can pinch, crush or cut. Keep clear and use caution.

Resources Required

- 2 screwdrivers
- Jack stands
- White grease or anti-seize compound
- Straight edge
- Cotter pin

AXLES AND SUSPENSION

Maintenance Steps

⚠ WARNING

Prior to testing or adjusting brakes, make sure area is clear of any persons and vehicles. Failure to perform test may result in serious personal injury, severe product or property damage, or voiding of the component warranty.

⚠ WARNING

Lift the trailer by its frame and never the axle or suspension. Do not go under the trailer unless it is properly supported by jack stands. Unsupported trailers can fall causing serious injury or death.

Brake Adjustment

The Lippert Electric Brakes are offered in a manual and automatic adjusting form. If manual brake adjusting is required, do as follows:

1. Jack up trailer and secure on adequate capacity jack stands.
 - A. Follow trailer manufacturer's recommendations for lifting and supporting the trailer.
 - B. Make sure the wheel and drum rotate freely.
2. Remove the adjusting hole cover from the adjusting slot on the bottom of the brake backing plate.
3. With a screwdriver or standard adjusting tool, rotate the starwheel of the adjuster assembly to expand the brake shoes.
 - A. Adjust the brake shoes out until the pressure of the linings against the drum makes the wheel very difficult to turn.
4. Rotate the starwheel in the opposite direction until the wheel turns freely with a slight lining drag, or approximately 10 click adjustments.

NOTE: A second screwdriver will be needed to push the auto adjusting lever away from the adjuster starwheel so that the starwheel can be rotated backward in the case of a self-adjusting brake.

5. Replace the adjusting hole cover and lower the wheel to the ground.
6. Repeat the above procedure on all brakes.

NOTE: For best results, the brakes should all be set at the same clearance. If the first brake's clearance was adjusted to 10 clicks, then adjust the remaining brake clearances to the same amount.

Lubricate Brakes

Prior to reassembling the brake drum assembly, do as follows:

1. Apply a light film of white grease or an anti-seize compound to:
 - A. The brake anchor pin,
 - B. The actuating arm bushing and pin,
 - C. The areas of the backing plate that are in contact with the brake shoes and magnet lever arm,
 - D. And on the actuating block mounted to the actuating arm.

Clean and Inspect Brakes

In the event the braking system encounters symptoms of improper application or failure, immediate inspection and service **MUST** be implemented. During normal use, servicing the braking system once a year is considered normal. Above normal use will require servicing based on a 3,000-6,000 mile increment schedule. Change worn magnets and shoes as needed to maintain maximum braking capability.

AXLES AND SUSPENSION

When disassembling the brakes for cleaning, make sure to:

1. Clean the backing plate, magnet arm, magnet and shoes.
2. Make sure all parts removed for cleaning are placed back into the same brake drum assembly.
3. Check for parts that have become loose or worn.
 - A. Service or replace loose or worn parts.

Magnets

The Lippert Electric Braking System uses high-quality electromagnets to actuate the brake shoes. These electromagnets provide superior force and friction to safely, and effectively, stop the trailer. Inspect and service the electromagnets annually if the trailer has seen normal use, more often if the trailer is used extensively. Inspect the electromagnets and do as follows:

1. Use a straight edge to check the electromagnet for uneven wear (Fig. 1).

NOTE: Figure 1 shows an electromagnet with little or no wear.

- A. Surface of electromagnet should be completely flat.
 - B. If abnormal or uneven wear is indicated by pronounced gaps, replace the electromagnet.
2. If the magnet's coil is exposed in any way, even if normal wear is evident, the magnets should be replaced immediately.
 - A. If the electromagnets are replaced, the drum armature surface should be refaced.
3. If an electromagnet is replaced on one side of an axle, Lippert recommends replacing the electromagnet on the opposite brake assembly. This will ensure an even braking capacity.

Fig. 1

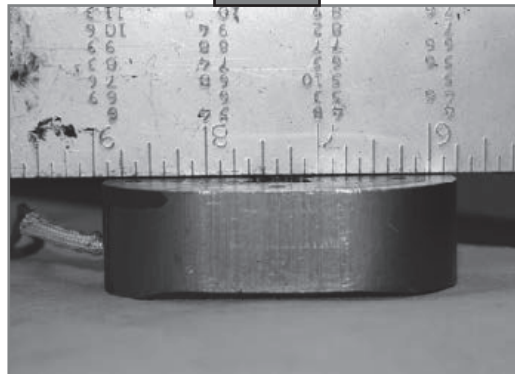

Shoes and Linings

Inspect brake shoes and linings for:

1. Grease or oil.
2. Surface scoring, pitting or gouges.
3. Replace both shoes if lubricant contamination or physical damage is present, even if found on only one shoe.
 - A. Replace both shoes (two) on the brake and on both brakes (four) installed on the same axle. Replace brake parts at the same time. This will ensure an even braking capacity.
4. Measure lining thickness.
 - A. Lining thickness shall not be less the 1/16".
 - I. If lining measures less than 1/16", replace the shoe.
 - II. Repeat step 3A.
5. Heat cracks are normal and rarely require attention.

AXLES AND SUSPENSION

After replacing the brake shoes and linings, burnish-in trailer brakes as follows:

1. Apply the brakes 20-30 times over a 20 mph decreasing speed range.
 - A. For example, brake 20-30 times while decreasing in speed from 40 mph to 20 mph.
 - B. Make sure ample time is allowed for brakes to cool between application.
 - I. The cooling period allows the brake shoes and magnets to begin seating to the brake drum.

Maintenance Schedule

Item	Function Required	3 Months or Every 3,000 Miles - whichever comes first	12 Months or Every 36,000 Miles - whichever comes first
Brakes	Test that they are operational.	At Every Use	
Oil Level	Check oil level in hubs, if equipped.	At Every Use	
Brake Adjustment	Adjust to proper operating clearance. Not required for self-adjusting brakes.	◆	
Brake Magnets	Inspect for wear and current draw.		◆
Brake Linings and Pads	Inspect for wear or contamination.		◆
Hub/Drum and Rotors	Inspect for abnormal wear or scoring		◆
Wheel Bearing	Inspect for corrosion or wear. Clean and repack		◆
Seals	Inspect for leakage. Replace if removed.		◆
Springs	Inspect for wear, loss of arch.		◆
Suspension Parts	Inspect for bending, loose fasteners, wear.		◆
U-bolts	Tighten to specified torque values.		◆

As a supplier of a broad array of highly-engineered components in the recreation and transportation product markets, safety, education and customer satisfaction are our primary concerns. Should you have any questions, please do not hesitate to contact us at 432-LIPPERT (432-547-7378) or by email at customerservice@lci1.com. Self-help tips, technical documents, product videos and a training class schedule are available at lippert.com or by downloading the LippertNOW app.

Breakaway Battery Charger Installation Instructions for: ABCD® (Accelerated Battery Charging Device) TOW CHARGER 12 Volt Lead-Acid Battery

READ THIS FIRST:
Check condition of battery prior to installation and prior to each trip.

1. Remove Charger and Battery from the battery case.
2. Mount battery case securely to frame, jack post or other suitable location on trailer.
3. Bolt Breakaway Switch® to frame of trailer or battery case bracket.
4. Disconnect trailer from tow vehicle. Install battery and charger into the battery case. Feed wires out the back, then close the top.
5. Wire per schematic diagram. Properly insulate all connections.
6. For Technical Assistance and Warranty Information call: 1-888-785-5832 or www.tekonsha.com

Important Facts to Remember

1. **CAUTION** USE ZIP TIE TO SECURE COVER. To prevent accidental opening of the Battery Box, Use a UV-Resistant Zip Tie to Secure the Cover to the Box using one or both of the holes provided.
2. **CAUTION** Improper installation of the breakaway battery will destroy the brake control. The negative (-) terminal must attach to ground and positive (+) terminal must attach to the breakaway switch.
3. **WARNING** Check your Breakaway System® periodically to insure that wiring and connections are secure. A short or an open circuit can result in a no-brake condition.
4. If excessive discharging of the breakaway battery occurs, check battery and recharge using a Heavy Duty Multi Stage/Maintenance Charger. Tekonsha charger 2024-07 is recommended for proper charging.
5. If the secondary battery needs charging, current will be drawn from the tow vehicle's battery at anytime the tow vehicle is connected to the trailer. Tekonsha charger 2024-07 is recommended for proper charging.
6. To only charge the breakaway battery when vehicle is running, a battery isolator may be installed in the 12 volt supply line (RED wire for tow charger).

Printed in Mexico
Imprimé au Mexique
Impreso en México
P/N: 2218 REV S 09/13

© 2013 Cequent Performance Products

12 Volt Sealed Lead-Acid Battery To maximize the life of the battery the following conditions should be met:

1. Avoid over or undercharge. This is the single worst enemy of lead-acid batteries.
2. Batteries should not be stored in a discharged state or at elevated ambient temperatures.
3. Avoid exposing batteries to heat! Service life is shortened considerably at ambient above 30°C (86°F).
4. Due to the characteristics of this battery, after six to nine months of storage, the battery should be recharged.
5. Charge the battery at the proper rate. Current should be limited to 1.2 amps or less.
6. Provide adequate air circulation when charging battery. Do not charge battery in any other container besides the supplied battery box.
7. **CAUTION** Do not place batteries in close proximity to objects which can produce sparks or flames.
8. Do not expose battery case to organic solvents or adhesives.
9. **CAUTION** Do not attempt to disassemble batteries. Contact with sulfuric acid may cause harm.
10. **CAUTION** Fasten batteries tightly and make provisions for shock absorption if exposure to shock or vibration is likely.
11. **WARNING** Do not throw batteries into fire; batteries so disposed may rupture or explode.

Battery Data Chart

- 12 VOLT
- Maximum charge current must be limited to 1.2 amps
- Length = 3.54" Width = 2.76" Height = 4.13" Terminals: Fasten Tab .187" x .032"
- **Service Life:**
Under normal operating conditions, 4-5 years in standby applications or 200-1000 charged/discharge cycles depending upon depth of discharge and rate of charge.

HEAVY DUTY QUICK/MAINTENANCE MULTI STAGE CHARGER

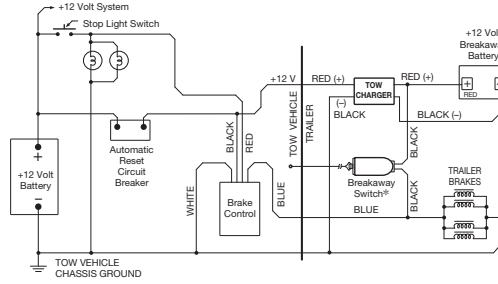

ABCD (Accelerated Battery Charging Device)

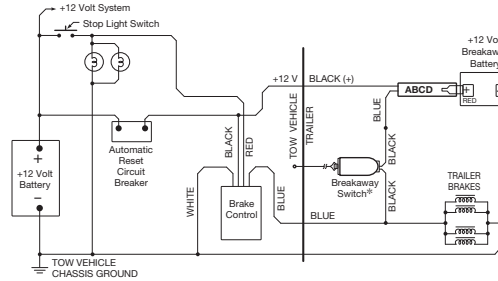

* Refer to Breakaway Switch Installation Instructions for complete operating instructions and cautionary statements.

BREAKAWAY SWITCH INSTALLATION INSTRUCTIONS

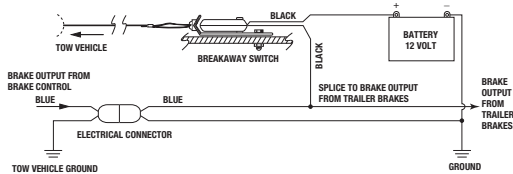

READ THIS FIRST:
Read and follow all instructions carefully before installing or operating the Breakaway Switch. Keep these instructions for future reference.

Important Facts to Remember

1. **ATTENTION INSTALLER:** Please give this sheet to consumer upon completion of installation.
2. **SAFETY ITEM:** Solder all wire connections.
3. Check condition of battery prior to each trip.
4. **WARNING** Disconnect trailer plug before testing breakaway unit. Failure to do so will result in severe damage to electronic brake control.
5. **WARNING** Check your breakaway system periodically to insure that wiring and connections are secure. A short or an open circuit can result in a no-brake condition.
6. For optimal performance, it is recommended that breakaway devices be replaced every 3-5 years.
7. For Technical Assistance and Warranty Information call: 1-888-785-5832 or www.tekonsha.com

Installation Guide

1. Mount Battery Case securely to frame, jack post or other suitable location on trailer with Breakaway Switch Cable towards tow vehicle.
2. **WARNING** Switch location should be selected to ensure unobstructed line of pull in event of vehicle separation.
3. Bolt breakaway switch bracket to frame of trailer or battery case bracket using 1/4" bolt and lock nut or (2) 1/4" jam nuts. (Bolt and nuts not included in kit.)
4. **WARNING** Do not over tighten bolt. Switch must be able to pivot.
5. Disconnect trailer from tow vehicle. Check and install battery.
6. Wire per schematic. Properly insulate all connections.
7. Attaching to tow vehicle: Attach Breakaway Switch Cable to tow vehicle frame being certain the cable does not drag on the ground and no strain or restriction is placed on the cable.
8. **WARNING** Do not hook cable to safety chain loop or hitch ball.